



PED Certified | OHSAS 18001:2007 | ISO 9001 : 2008 | ISO 14001:2004 | Govt.
Recog. Export House.

**Manufacturer, Exporter, Stockiest, Supplier, Trader for
Carbon Steel, Stainless Steel, Alloy Steel for Seamless, Welded,
ERW, LSAW, DSAW, HSAW, HFI, EFW Pipes.**

Hot finished structural hollow sections of non-alloy and fine grain steels —

Part 1: Technical delivery conditions

The European Standard EN 10210-1:2006 has the status of a British Standard

ICS 77.140.75

National foreword

This British Standard is the official English language version of EN 10210-1:2006. It supersedes BS EN 10210-1:1994 which is withdrawn.

The UK participation in its preparation was entrusted to Technical Committee ISE/12, Structural steels, which has the responsibility to:

- aid enquirers to understand the text;
- present to the responsible international/European committee any enquiries on the interpretation, or proposals for change, and keep UK interests informed;
- monitor related international and European developments and promulgate them in the UK.

A list of organizations represented on this committee can be obtained on request to its secretary.

Cross-references

The British Standards which implement international or European publications referred to in this document may be found in the *BSI Catalogue* under the section entitled “International Standards Correspondence Index”, or by using the “Search” facility of the *BSI Electronic Catalogue* or of British Standards Online.

This publication does not purport to include all the necessary provisions of a contract. Users are responsible for its correct application.

Compliance with a British Standard does not of itself confer immunity from legal obligations.

Summary of pages

This document comprises a front cover, an inside front cover, the EN title page, pages 2 to 38, an inside back cover and a back cover.

The BSI copyright notice displayed in this document indicates when the document was last issued.

Amendments issued since publication

Amd. No.	Date	Comments

This British Standard was published under the authority of the Standards Policy and Strategy Committee on 31 May 2006

© BSI 2006

ISBN 0 580 46976 X

English Version

Hot finished structural hollow sections of non-alloy and fine grain steels - Part 1: Technical delivery conditions

Profils creux pour la construction finis à chaud en aciers non alliés et à grains fins - Partie 1 : Conditions techniques de livraison

Warmgefertigte Hohlprofile für den Stahlbau aus unlegierten Baustählen und aus Feinkornbaustählen - Teil 1: Technische Lieferbedingungen

This European Standard was approved by CEN on 16 March 2006.

CEN members are bound to comply with the CEN/CENELEC Internal Regulations which stipulate the conditions for giving this European Standard the status of a national standard without any alteration. Up-to-date lists and bibliographical references concerning such national standards may be obtained on application to the Central Secretariat or to any CEN member.

This European Standard exists in three official versions (English, French, German). A version in any other language made by translation under the responsibility of a CEN member into its own language and notified to the Central Secretariat has the same status as the official versions.

CEN members are the national standards bodies of Austria, Belgium, Cyprus, Czech Republic, Denmark, Estonia, Finland, France, Germany, Greece, Hungary, Iceland, Ireland, Italy, Latvia, Lithuania, Luxembourg, Malta, Netherlands, Norway, Poland, Portugal, Romania, Slovakia, Slovenia, Spain, Sweden, Switzerland and United Kingdom.



EUROPEAN COMMITTEE FOR STANDARDIZATION
COMITÉ EUROPÉEN DE NORMALISATION
EUROPÄISCHES KOMITEE FÜR NORMUNG

Management Centre: rue de Stassart, 36 B-1050 Brussels

Contents

	Page
Foreword.....	3
1 Scope	4
2 Normative references	4
3 Terms, definitions and symbols	5
3.1 Terms and definitions	5
3.2 Symbols	6
4 Classification and designation	6
4.1 Classification	6
4.2 Designation.....	6
5 Information to be obtained by the manufacturer	7
5.1 Mandatory information	7
5.2 Options.....	7
5.3 Example of an order.....	8
6 Requirements	8
6.1 General.....	8
6.2 Steel manufacturing process.....	8
6.3 Structural hollow section manufacturing process	8
6.4 Delivery condition	9
6.5 Chemical composition.....	9
6.6 Mechanical properties	10
6.7 Technological properties	11
6.8 Surface condition.....	12
6.9 Non-destructive testing of welds.....	12
6.10 Tolerances and mass.....	12
7 Inspection	12
7.1 Types of inspection	12
7.2 Types of inspection document	13
7.3 Summary of inspection	13
8 Sampling	15
8.1 Frequency of tests	15
8.2 Preparation of samples and test pieces	16
9 Test methods.....	17
9.1 Chemical analysis	17
9.2 Mechanical tests	18
9.3 Visual inspection and dimensional check	18
9.4 Non-destructive testing	19
9.5 Retests, sorting and reprocessing	19
10 Marking	19
11 Evaluation of conformity	20
Annex A (normative) Structural hollow sections of non-alloy quality steels — Chemical composition and mechanical properties	21
Annex B (normative) Structural hollow sections of fine grain steels — Chemical composition and mechanical properties	23
Annex C (normative) Location of samples and test pieces	26
Annex D (normative) Evaluation of conformity.....	28
Annex ZA (informative) Clauses of this European Standard addressing the provisions of the EU Construction Products Directive.....	33
Bibliography	38

Foreword

This European Standard (EN 10210-1:2006) has been prepared by Technical Committee ECISS/TC 10 "Structural steels - Grades and qualities", the secretariat of which is held by NEN.

This European Standard shall be given the status of a national standard, either by publication of an identical text or by endorsement, at the latest by October 2006, and conflicting national standards shall be withdrawn at the latest by October 2006.

This European Standard supersedes EN 10210-1:1994.

This European Standard has been prepared under a mandate given to CEN by the European Commission and the European Free Trade Association, and supports essential requirements of EU Directive(s).

For relationship with EU Directive(s), see informative Annex ZA, which is an integral part of this European Standard.

This standard consists of the following parts under the general title 'Hot finished structural hollow sections of non-alloy and fine grain steels':

- Part 1: Technical delivery conditions
- Part 2: Tolerances, dimensions and sectional properties

It forms part of a series of standards on hollow sections together with EN 10219-1 and 2, which are also under revision.

According to the CEN/CENELEC Internal Regulations, the national standards organizations of the following countries are bound to implement this European Standard: Austria, Belgium, Cyprus, Czech Republic, Denmark, Estonia, Finland, France, Germany, Greece, Hungary, Iceland, Ireland, Italy, Latvia, Lithuania, Luxembourg, Malta, Netherlands, Norway, Poland, Portugal, Romania, Slovakia, Slovenia, Spain, Sweden, Switzerland and United Kingdom.

1 Scope

This part of this European Standard specifies technical delivery conditions for hot finished hollow sections of circular, square, rectangular or elliptical forms and applies to hollow sections formed hot, with or without subsequent heat treatment, or formed cold with subsequent heat treatment to obtain equivalent metallurgical conditions to those obtained in the hot formed product.

Requirements for tolerances, dimensions and sectional properties are contained in EN 10210-2.

NOTE A range of material grades is specified in this standard and the user should select the grade appropriate to the intended use and service conditions. The grades and mechanical properties of the finished hollow sections are compatible with those in EN 10025-2 and EN 10025-3.

2 Normative references

The following referenced documents are indispensable for the application of this European Standard. For dated references, only the edition cited applies. For undated references, the latest edition of the referenced document (including any amendments) applies.

EN 287-1, *Qualification test of welders - Fusion welding - Part 1: Steels*

EN 10002-1, *Metallic materials — Tensile testing — Part 1: Method of test at ambient temperature*

EN 10020:2000, *Definition and classification of grades of steel*

EN 10021:1993, *General technical delivery requirements for steel and iron products*

EN 10027-1, *Designation systems for steels — Part 1: Steel names*

EN 10027-2, *Designation systems for steels - Part 2: Numerical system*

EN 10045-1, *Metallic materials — Charpy impact test — Part 1: Test method*

EN 10052:1993, *Vocabulary of heat treatment terms for ferrous products*

EN 10168, *Steel products - Inspection documents - List of information and description*

EN 10204, *Metallic products — Types of inspection documents*

EN 10210-2:2006, *Hot finished structural hollow sections of non-alloy and fine grain steels - Part 2: Tolerances, dimensions and sectional properties*

EN 10246-3, *Non-destructive testing of steel tubes — Part 3: Automatic eddy current testing of seamless and welded (except submerged arc-welded) steel tubes for the detection of imperfections*

EN 10246-5, *Non-destructive testing of steel tubes — Part 5: Automatic full peripheral magnetic transducer/flux leakage testing of seamless and welded (except submerged arc welded) ferromagnetic steel tubes for the detection of longitudinal imperfections*

EN 10246-8, *Non-destructive testing of steel tubes — Part 8: Automatic ultrasonic testing of the weld seam of electric welded steel tubes for the detection of longitudinal imperfections*

EN 10246-9, *Non-destructive testing of steel tubes — Part 9: Automatic ultrasonic testing of the weld seam of submerged arc welded steel tubes for the detection of longitudinal and/or transverse imperfections*

EN 10246-10, *Non-destructive testing of steel tubes — Part 10: Radiographic testing of the weld seam of automatic fusion arc welded steel tubes for the detection of imperfections*

EN 10256, *Non-destructive testing of steel tubes - Qualification and competence of level 1 and 2 non-destructive testing personnel*

CR 10261, *ECISS Information Circular 11 — Iron and steel — Review of available methods of chemical analysis*

EN 10266:2003, *Steel tubes, fittings and structural hollow sections - Symbols and definitions of terms for use in product standards*

EN ISO 377, *Steel and steel products - Location and preparation of samples and test pieces for mechanical testing (ISO 377:1997)*

EN ISO 643, *Steels - Micrographic determination of the apparent grain size (ISO 643:2003)*

EN ISO 2566-1, *Steel — Conversion of elongation values — Part 1: Carbon and low alloy steels (ISO 2566-1:1984)*

EN ISO 9001:2000, *Quality management systems — Requirements (ISO 9001:2000)*

EN ISO 14284, *Steel and iron - Sampling and preparation of samples for the determination of chemical composition (ISO 14284:1996)*

EN ISO 15607, *Specification and qualification of welding procedures for metallic materials - General rules (ISO 15607:2003)*

EN ISO 15609-1, *Specification and qualification of welding procedures for metallic materials - Welding procedure specification - Part 1: Arc welding (ISO 15609-1:2004)*

EN ISO 15614-1, *Specification and qualification of welding procedures for metallic materials - Welding procedure test — Part 1: Arc and gas welding of steels and arc welding of nickel and nickel alloys (ISO 15614-1:2004)*

3 Terms, definitions and symbols

3.1 Terms and definitions

For the purposes of this European Standard, the following terms and definitions apply in addition to or where different from those in EN 10020:2000, EN 10021:1993, EN 10052:1993 and EN 10266:2003.

3.1.1

cold forming

process where the main forming is done at ambient temperature

3.1.2

normalizing rolling

rolling process in which the final deformation is carried out in a certain temperature range leading to a material condition equivalent to that obtained after normalizing so that the specified values of the mechanical properties are retained even after subsequent normalizing

3.2 Symbols

For the purposes of this European Standard, the symbols defined in EN 10266:2003 apply.

4 Classification and designation

4.1 Classification

4.1.1 Within the strength grades of the non-alloy steels given in Annex A, four qualities JR, J0, J2 and K2 are specified. These differ in respect of specified impact requirements, method of deoxidation, limits on values of various elements, with particular reference to sulfur and phosphorus, and the inspection and testing requirements.

In accordance with the classification system in EN 10020, all steel grades in Annex A are non-alloy quality steels.

4.1.2 Within the strength grades of the fine grain steels given in Annex B, two qualities N and NL are specified. These differ in respect of the carbon, sulfur and phosphorus content, and low temperature impact properties.

In accordance with the classification system in EN 10020, steel grades S275NH, S275NLH, S355NH and S355NLH are non-alloy quality steels and steel grades S420NH, S420NLH, S460NH and S460NLH are alloy special steels.

4.2 Designation

4.2.1 For the products covered by this European Standard the steel names are allocated in accordance with EN 10027-1; the steel numbers are allocated in accordance with EN 10027-2.

4.2.2 For non-alloy steel hollow sections the steel designation consists of:

- the number of this European Standard (EN 10210-1);
- the capital letter S for structural steel;
- the indication of the minimum specified yield strength for thicknesses ≤ 16 mm expressed in MPa¹;
- the capital letters JR for the qualities with specified impact properties at room temperature, the characters J0 for the qualities with specified impact properties at 0 °C and the characters J2 or K2 for the qualities with specified impact properties at -20 °C;
- the capital letter H to indicate hollow sections.

EXAMPLE Structural steel (S) with a specified minimum yield strength for a thickness not greater than 16 mm of 275 MPa, with a minimum impact energy value of 27 J at 0 °C (J0), hollow section (H):

EN 10210-S275J0H

4.2.3 For fine grain steel structural hollow sections the steel designation consists of:

- number of this European Standard (EN 10210-1);

¹) 1 MPa = 1 N/mm²

- capital letter S for structural steel;
- indication of the minimum specified yield strength for thicknesses ≤ 16 mm expressed in MPa;
- capital letter N to indicate normalized or normalized rolled (see 6.4);
- capital letter L for the qualities with specified impact properties at -50 °C;
- capital letter H to indicate hollow sections.

EXAMPLE Structural steel (S) with a specified minimum yield strength for a thickness not greater than 16 mm of 355 MPa, normalized condition (N), with a minimum impact energy value of 27 J at -50 °C (L), hollow section (H):

EN 10210-S355NLH

5 Information to be obtained by the manufacturer

5.1 Mandatory information

The following information shall be obtained by the manufacturer at the time of enquiry and order:

- a) the quantity (mass or total length);
- b) the type of length, length range or length (see EN 10210-2);
- c) details of the product form:
 - HFCHS = hot finished circular hollow sections
 - HFRHS = hot finished square or rectangular hollow sections
 - HFEHS = hot finished elliptical hollow sections;
- d) the steel designation (see 4.2);
- e) the dimensions (see EN 10210-2).

5.2 Options

A number of options are specified in Parts 1 and 2 of this European Standard. Those relevant to this part are listed below with appropriate clause references. In the event that the purchaser does not indicate a wish to implement any of these options at the time of enquiry and order, the hollow sections shall be supplied in accordance with the basic specification.

- 1.1 Product analysis (see 6.5.1).
- 1.2 Cr, Cu, Mo, Ni, Ti and V cast analysis contents to be reported (see 6.5.2).
- 1.3 Verification of impact properties for qualities J0 and JR (see 6.6.4).
- 1.4 Suitability for hot dip galvanizing (see 6.7.2).
- 1.5 Weld repairs to the body of non-alloy structural steel hollow sections not permitted (see 6.8.4).
- 1.6 Specific inspection and testing for non-alloy quality grades JR and J0 (see 7.1.1).

EN 10210-1:2006 (E)

1.7 Inspection document other than the standard document (see 7.2.2).

1.8 Tensile test in corner region (see 8.2.3.1).

1.9 Impact test in corner region (see 8.2.3.2).

5.3 Example of an order

100 t of 12 m exact length hot finished square hollow section in accordance with EN 10210, made from non-alloy quality structural steel S355J0H, with specified outside dimensions 100 mm × 100 mm and wall thickness of 8 mm, supplied with specific inspection and testing (Option 1.6), verified impact properties at 0 °C (Option 1.3):

100 t 12 m Exact length – HFRHS – EN 10210– S355J0H – 100 × 100 × 8 – Options 1.3, 1.6

6 Requirements

6.1 General

Structural hollow sections of non-alloy steels shall conform to the requirements of Annex A. Structural hollow sections of fine grain steels shall conform to the requirements of Annex B.

In addition, the general technical delivery requirements specified in EN 10021 shall apply.

6.2 Steel manufacturing process

6.2.1 The steel manufacturing process shall be at the discretion of the steel producer.

6.2.2 For the non-alloy steels given in Annex A, the method of deoxidation shall be as specified in Table A.1.

6.2.3 For the fine grain steels given in Annex B the method of deoxidation shall be as specified in Table B.1.

6.3 Structural hollow section manufacturing process

6.3.1 Structural hollow sections shall be manufactured by a seamless or by a welding process. Welded sections manufactured by a continuous process shall not include the welds used to join the lengths of strip prior to forming the hollow section, except as permitted in 9.4.3.

6.3.2 The fine grain steels given in Annex B shall have a ferritic grain size equal to or finer than 6 when measured in accordance with EN ISO 643 (see 6.6.3).

6.3.3 Electric welded hollow sections are normally supplied without trimming the internal weld bead.

6.3.4 All NDT activities shall be carried out by qualified and competent level 1, 2 and/or 3 personnel authorised to operate by the employer.

The qualification shall be in accordance with EN 10256 or, at least, an equivalent to it.

It is recommended that the level 3 personnel be certified in accordance with EN 473 or, at least, an equivalent to it.

The operating authorisation issued by the employer shall be in accordance with a written procedure.

NDT operations shall be authorised by a level 3 NDT individual approved by the employer.

NOTE The definition of levels 1, 2 and 3 can be found in the appropriate standards, e.g. EN 473 and EN 10256.

6.4 Delivery condition

The products shall be delivered in the conditions indicated below:

Qualities JR, J0, J2 and K2 — hot finished,

Qualities N and NL — normalized. Normalized includes normalized rolled.

It may be necessary for seamless hollow sections with a wall thickness above 10 mm, or when T/D is greater than 0,1, to apply accelerated cooling after austenitizing to achieve the intended structure, or liquid quenching and tempering to achieve the specified mechanical properties. The decision shall be left to the discretion of the manufacturer, but shall be stated to the purchaser at the time of enquiry and order. Hollow sections treated in such a way shall be designated:

- for accelerated cooling: by the steel name supplemented by the symbol "+DC";
- for quenching and tempering:
 - a) by the steel name supplemented by the symbol "+QT" in the case of non alloy steels;
 - b) by a modified steel name for which the letter N is replaced by Q in the case of fine grain steels e.g. S460QLH.

NOTE Cold formed hollow sections with subsequent heat treatment to obtain properties equivalent to those obtained by normalizing rolling are deemed to meet the requirements of this standard.

6.5 Chemical composition

6.5.1 The cast analysis reported by the steel producer shall apply and shall conform to the requirements given in Table A.1 or Table B.1.

The maximum carbon equivalent value (CEV) for all grades, based on the cast analyses, given in Table A.2 or Table B.2, shall apply.

When determining the CEV the following formula shall be used:

$$CEV = C + \frac{Mn}{6} + \frac{Cr + Mo + V}{5} + \frac{Ni + Cu}{15}$$

Option 1.1 for products supplied with specific inspection and testing, a product analysis shall be reported.

Deviations of the product analysis from the specified limits of the cast analysis shall be in accordance with Table 1.

Table 1 — Permissible deviations of the product analysis from the specified limits of the cast analysis specified in Tables A.1 and B.1

Element	Permissible maximum content in the cast analysis % by mass	Permissible deviation of the product analysis from specified limits for the cast analysis % by mass
C ^a	≤ 0,20	+ 0,02
	> 0,20	+ 0,03
Si	≤ 0,60	+ 0,05
Mn	non-alloy ≤ 1,60	+ 0,10
	fine grain ≤ 1,70	− 0,05 + 0,10
P	non-alloy ≤ 0,040	+ 0,010
	fine grain ≤ 0,035	+ 0,005
S	non-alloy ≤ 0,040	+ 0,010
	fine grain ≤ 0,030	+ 0,005
Nb	≤ 0,060	+ 0,010
V	≤ 0,20	+ 0,02
Ti	≤ 0,03	+ 0,01
Cr	≤ 0,30	+ 0,05
Ni	≤ 0,80	+ 0,05
Mo	≤ 0,10	+ 0,03
Cu	≤ 0,35	+ 0,04
	0,35 < Cu ≤ 0,70	+ 0,07
N	≤ 0,025	+ 0,002
Al _{total}	≥ 0,020	− 0,005

^a For S235JRH in thicknesses ≤ 16 mm, the permissible deviation = 0,04 % C, and for thicknesses > 16 mm and ≤ 40 mm the permissible deviation = 0,05 % C.

6.5.2 For non-alloy steel products supplied with specific inspection and testing the following option may be specified (see 7.1):

Option 1.2 the recording on the inspection certificate of the Cr, Cu, Mo, Ni, Ti and V content (cast analysis).

6.6 Mechanical properties

6.6.1 Under the inspection and testing conditions as specified in Clause 7 and in the delivery condition as specified in 6.4, the mechanical properties shall conform to the relevant requirements of Table A.3 or Table B.3.

NOTE Stress relief annealing at more than 580 °C or for over one hour may lead to deterioration of the mechanical properties.

6.6.2 For impact tests, standard V-notch test pieces in accordance with EN 10045-1 shall be used. If the nominal product thickness is not sufficient for the preparation of standard test pieces, the test shall be carried out using test pieces of width less than 10 mm, but not less than 5 mm. The minimum average values given in Table A.3 and Table B.3 shall be reduced in direct proportion to the actual width of the test piece compared to that of the standard test piece.

Impact tests are not required for specified thicknesses < 6 mm.

6.6.3 For fine grain steel hollow sections in thicknesses which do not permit impact test pieces of width ≥ 5 mm to be taken, the ferritic grain size (see 6.3.2) shall be verified by the method as described in EN ISO 643.

When aluminium is used as the grain refining element, the grain size requirement shall be deemed to be fulfilled if the cast analysis shows the aluminium content to be not less than 0,020 % total aluminium or alternatively 0,015 % soluble aluminium. In these cases, verification of the grain size is not required.

6.6.4 Subject to the limitations of 6.6.2

- a) the impact properties of structural hollow sections of steel qualities J2, K2, N, NL, Q and QL shall be verified;
- b) the impact properties of structural hollow sections of steel qualities JR and J0 are not verified unless otherwise specified by the purchaser at the time of enquiry and order.

Option 1.3 for products in qualities JR and J0 supplied with specific inspection and testing (see Option 1.6), the verification of the impact properties is specified.

6.7 Technological properties

6.7.1 Weldability

The steels specified in this European Standard are weldable. General requirements for welding of the products in accordance with this European Standard are given in EN 1011-1 and EN 1011-2.

NOTE 1 When welding these products, as product thickness, strength level and CEV increase, the occurrence of cold cracking in the welded zone forms the main risk. Cold cracking is caused by a combination of the following factors:

- high levels of diffusible hydrogen in the weld metal;
- a brittle structure in the heat affected zone;
- significant tensile stress concentrations in the welded joint.

NOTE 2 By using guidelines, specified for example in EN 1011-1, EN 1011-2 or any other relevant standard, the recommended welding conditions and the various welding ranges for the steel grades can be determined. These will vary depending on the product thickness, the applied welding energy, the design requirements, the electrode efficiency, the welding process and the weld metal properties.

6.7.2 Suitability for hot dip galvanizing

Option 1.4 the products shall be suitable for hot dip galvanizing.

6.8 Surface condition

6.8.1 The hollow sections shall have a smooth surface corresponding to the manufacturing method used; bumps, cavities or shallow longitudinal grooves resulting from the manufacturing process are permissible, provided the thickness is within tolerance.

Surface defects may be removed by the manufacturer by grinding, provided that the thickness of the hollow section after the repair is not less than the minimum permissible thickness in accordance with EN 10210-2.

6.8.2 The ends of the hollow section shall be cut nominally square to the axis of the product.

6.8.3 For both non-alloy and fine grain hollow sections manufactured by a welded process, repair of the weld shall not be permitted except for submerged arc welds.

6.8.4 For non-alloy hollow sections manufactured by either a seamless or welding process, repair of the body by welding shall be permitted unless otherwise specified. The conditions under which, and the extent to which, welding repair to the body may be carried out shall be agreed between the manufacturer and the purchaser.

Option 1.5 repair of the body by welding shall not be carried out.

For fine grain structural steel hollow sections manufactured by either a seamless or welded process, repair of the body by welding shall not be permitted unless otherwise agreed.

6.8.5 Welding repair shall be carried out by operators qualified in accordance with EN 287-1. Welding procedures shall be in accordance with EN ISO 15607, EN ISO 15609-1 and EN ISO 15614-1.

6.8.6 The repaired hollow section shall conform to all the requirements of this European Standard.

6.9 Non-destructive testing of welds

The seam weld of all welded hollow sections supplied with specific inspection and testing shall be subjected to a non-destructive test in accordance with 9.4.

6.10 Tolerances and mass

6.10.1 Tolerances

Tolerances shall be as specified in EN 10210-2.

6.10.2 Mass

Mass shall be determined using a density of 7,85 kg/dm³.

NOTE Dimensions, sectional properties and mass per unit length for a limited range of sizes of hot finished structural hollow sections are given in EN 10210-2. The purchaser should preferably select hollow section dimensions from this limited range of sizes.

7 Inspection

7.1 Types of inspection

7.1.1 Non-alloy steel hollow sections of qualities JR and J0 (see Annex A) shall be supplied with non-specific inspection in accordance with EN 10021 unless Option 1.6 is specified.

Option 1.6 qualities JR and J0 shall be supplied with specific inspection.

7.1.2 Non-alloy steel hollow sections of qualities J2 and K2 (see Annex A) and fine grain steels of qualities N and NL (see Annex B) shall be supplied with specific inspection in accordance with EN 10021.

7.2 Types of inspection document

7.2.1 For products supplied with non-specific inspection a test report (2.2) in accordance with EN 10204 shall be provided.

The test report shall contain the following codes and relevant information in accordance with EN 10168.

A — Commercial transactions and parties involved.

B — Description of products to which the test report applies.

C — Information on tests as follows:

C10-C13 — Tensile test;

C71-C92 — Cast analysis.

Z — Validation.

7.2.2 For products supplied with specific inspection an inspection certificate 3.1 in accordance with EN 10204 shall be supplied unless Option 1.7 is specified.

Option 1.7 an inspection certificate 3.2 in accordance with EN 10204 shall be supplied. Where this document is specified, the purchaser shall notify the manufacturer of the address of the organization or person nominated by him to carry out the inspection and validate the inspection document. It shall also be agreed which party shall issue the certificate.

The inspection certificate shall contain the following codes and related information in accordance with EN 10168:

A — Commercial transactions and parties involved.

B — Description of products to which the inspection certificate applies.

C — Information on tests as follows:

C02-C03 — Direction of test pieces and test temperature;

C10-C13 — Tensile test — Test piece shape and test results;

C40-C43 — Impact test — Test piece type and test results, if applicable;

C71-C92 — Cast analysis and, if applicable, product analysis.

Z — Validation.

7.3 Summary of inspection

The requirements for inspection are given in Table 2 for hollow sections of non-alloy steels and in Table 3 for hollow sections of fine grain steels.

Table 2 — Inspection programme for non-alloy steels in accordance with Annex A

Inspection requirements				Inspection programme	
Type of test			Subclause reference(s)	Non-specific inspection	Specific inspection
Mandatory tests	1	Cast analysis	6.5 9.1	One result per delivery item	One per cast
	2	Tensile test	6.6 9.2	One result per delivery item	One per test unit ^{a,b}
	3	Impact test for qualities J2 and K2 only	6.6 9.2	Not applicable	One set per test unit ^{a,b}
	4	Surface condition and dimensions	6.8 6.10 9.3	See 9.3	See 9.3
	5	For welded products NDT of the weld	6.9 9.4	Not applicable	All products, full length
Optional tests	6	Product analysis (Option 1.1)	6.5 9.1	Not applicable	One per test unit ^a
	7	Cast analysis additional elements (Option 1.2)	6.5 9.1	Not applicable	See option 1.2
	8	Impact test for qualities JR and J0 (Option 1.3)	6.6 9.2	Not applicable	One set per test unit ^{a,b}
	9	Tensile test in corner region (Option 1.8)	6.6 9.2	One result per delivery item	One per test unit ^a
	10	Impact test in corner region (Option 1.9)	6.6 9.2	Not applicable	One set per test unit ^a
^a For test unit see 8.1.3. ^b Longitudinal or transverse samples at the discretion of the manufacturer.					

Table 3 — Inspection programme for fine grain steels in accordance with Annex B

Inspection requirements			Inspection programme	
Type of test		Subclause reference(s)		Specific inspection
Mandatory tests	1	Cast analysis	6.5 9.1	One per cast
	2	Tensile test	6.6 9.2	One per test unit ^{ab}
	3	Impact test	6.6 9.2	One set per test unit ^{ab}
	4	Surface condition and dimensions	6.8 6.10 9.3	see 9.3
	5	For welded products NDT of the weld	6.9 9.4	All products, full length
Optional tests	6	Product analysis (Option 1.1)	6.5 9.1	One per test unit ^a
	7	Tensile test in corner region (Option 1.8)	6.6 9.2	One per test unit ^a
	8	Impact test in corner region (Option 1.9)	6.6 9.2	One set per test unit ^a
^a For test unit see 8.1.3.				
^b Longitudinal or transverse samples at the discretion of the manufacturer				

8 Sampling

8.1 Frequency of tests

8.1.1 For products supplied with non-specific inspection, see Table 2.

8.1.2 For products supplied with specific inspection, the verification of the mechanical properties and product analysis, if applicable, shall be carried out by test unit. A test unit is defined as a quantity of hollow sections from one or more cast(s) of the same grade and dimensions, manufactured by the same process (i.e. electric welding, submerged arc welding or seamless), and, if applicable, in the same heat treatment condition, submitted for acceptance at the same time.

The following samples shall be taken from one sample product of each test unit:

- 1 sample for tensile testing;
- 1 sample sufficient for 2 sets of 3 impact test pieces;

— 1 sample for product analysis, when required, see 8.2.1.

8.1.3 The mass of a test unit shall not exceed the maximum tonnage of sections specified in Table 4.

Table 4 — Test units

Type of hollow section		Test unit
Circular	Square, rectangular or elliptical	
Outside diameter <i>D</i> mm	External perimeter mm	Mass maximum t
≤ 114,3	≤ 400	40
> 114,3 ≤ 323,9	> 400 ≤ 800	50
> 323,9	> 800	75

8.2 Preparation of samples and test pieces

8.2.1 Selection and preparation of samples for chemical analysis

Samples for product analysis, when required shall be taken from the sample product or alternatively from test pieces used for mechanical testing or from the full thickness of the hollow section at the same location as for the mechanical test samples. The preparation of samples shall be in accordance with EN ISO 14284.

8.2.2 Preparation of test pieces for mechanical tests

8.2.2.1 General

The requirements of EN ISO 377 shall apply in conjunction with the test piece location specified in 8.2.3.

8.2.2.2 Tensile test pieces

The requirements of EN 10002-1 as appropriate shall apply.

Test pieces may be non-proportional, but in cases of dispute proportional test pieces having a gauge length $L_0 = 5,65 \sqrt{S_0}$ shall be used (see 9.2.2). For thicknesses less than 3 mm, a gauge length of $L_0 = 80$ mm shall be used, provided a test piece width of 20 mm can be achieved, otherwise a gauge length of 50 mm shall be used with a test piece width of 12,5 mm.

8.2.2.3 Impact test pieces

Impact V-notch test pieces shall be machined and prepared in accordance with EN 10045-1. In addition, the following requirements shall apply:

- a) for specified thicknesses > 12 mm, standard test pieces shall be machined in such a way that one side is not further away than 2 mm from a rolled surface;

- b) for specified thicknesses ≤ 12 mm, when test pieces with reduced sections are used, the width shall be ≥ 5 mm.

NOTE Test piece size is dependent on the actual thickness of the sample and, for circular or elliptical hollow sections; allowance also needs to be made for the curvature of the section.

8.2.3 Location and orientation of samples for mechanical tests

8.2.3.1 Tensile test pieces

The test pieces for tensile testing shall conform to the following:

- a) the test piece may be the full section of the product;
- b) for circular or elliptical sections, not tested in full section, the test pieces shall be taken either longitudinally or transversely, at the discretion of the manufacturer, and, for welded sections, at a point remote from the weld (see Annex C);
- c) for square or rectangular sections, not tested in full section, the test pieces shall be taken either longitudinally or transversely, at the discretion of the manufacturer, midway between the corners, and, for welded sections, from one of the sides not containing the weld (see Annex C).

Option 1.8 longitudinal test pieces shall be taken from one of the corner regions, but remote from the weld in welded sections, (see Annex C).

8.2.3.2 Impact test pieces

Test pieces for impact testing shall conform to the following:

- a) for circular or elliptical sections the test pieces shall be taken either longitudinally or transversely, at the discretion of the manufacturer, and, for welded sections, at a point remote from the weld (see Annex C);
- b) for square or rectangular sections the test pieces shall be taken either longitudinally or transversely, at the discretion of the manufacturer, midway between the corners, and, for welded sections, from one of the sides not containing the weld (see Annex C).

Option 1.9 longitudinal test pieces shall be taken from one of the corner regions, but remote from the weld in welded sections, (see Annex C) with the notch orientated towards the outer radius of the corner.

9 Test methods

9.1 Chemical analysis

The elements to be determined and reported shall be those given in Table A.1, and Option 1.2 if specified, or those in Table B.1, as applicable.

The choice of a suitable physical or chemical analytical method for the analysis shall be at the discretion of the manufacturer.

In case of dispute, the method used shall be agreed taking into account CR 10261.

9.2 Mechanical tests

9.2.1 Test temperature

Tensile tests shall be carried out in the temperature range 10 °C to 35 °C. Impact tests shall be carried out at the temperatures specified in Table A.3 for non-alloy steels and Table B.3 for fine grain steels.

9.2.2 Tensile tests

The tensile test shall be carried out in accordance with EN 10002-1.

For the specified yield strengths in Tables A.3 and B.3, the upper yield strength (R_{eH}) shall be determined.

If a yield phenomenon is not present, the 0,2 % proof strength non-proportional extension ($R_{p0,2}$) or the 0,5 % proof strength total extension ($R_{t0,5}$) shall be determined. In cases of dispute, the 0,2 % proof strength ($R_{p0,2}$) shall apply.

If a non-proportional test piece is used, the percentage elongation value obtained after fracture (A) shall be converted to the value for a gauge length $L_o = 5,65 \sqrt{S_o}$ using the conversion tables given in EN ISO 2566-1.

For thicknesses less than 3 mm, the percentage elongation may be reported for a gauge length of 80 mm or 50 mm (see 8.2.2.2). In this case the values to be achieved shall be agreed between the purchaser and the manufacturer at the time of enquiry and order.

9.2.3 Impact tests

The impact test shall be carried out in accordance with EN 10045-1. In addition, the following requirements shall apply:

- a) The average value of a set of three test pieces shall be equal to or greater than the specified value. One individual value may be below the specified value, provided that it is not less than 70 % of that value;
- b) If the conditions under a) are not satisfied then an additional set of three test pieces may be taken, at the discretion of the manufacturer, from the same sample and tested. To consider the test unit as conforming after testing the second set, the following conditions shall all be satisfied simultaneously:
 - 1) The average value of the six tests shall be equal to or greater than the minimum specified value;
 - 2) Not more than two of the six individual values may be lower than the minimum specified value;
 - 3) Not more than one of the six individual values may be lower than 70% of the minimum specified value;
- c) If these conditions are not satisfied, the sample product is rejected and retests shall be carried out on the remainder of the test unit (see 9.5).

9.3 Visual inspection and dimensional check

9.3.1 Visual inspection

The hollow sections shall be visually inspected for compliance with the requirements of 6.8.

9.3.2 Dimensional check

The dimensions of the hollow sections shall be checked for compliance with the requirements of EN 10210-2.

9.4 Non-destructive testing

9.4.1 General

When the welds of welded structural hollow sections are to be subjected to non-destructive testing, the method shall be in accordance with 9.4.2 or 9.4.3. At the manufacturer's discretion, the non-destructive testing may be carried out either on the circular shape prior to final forming or on the round, square, rectangular or elliptical hollow sections after final forming.

9.4.2 Electric welded sections

The weld seam of electric welded hollow sections shall be tested in accordance with one of the following European Standards. The standard to be applied is at the discretion of the manufacturer.

- a) EN 10246-3 to acceptance level E4, with the exception that the rotating tube/pancake coil technique shall not be permitted;
- b) EN 10246-5 to acceptance level F5;
- c) EN 10246-8 to acceptance level U5.

9.4.3 Submerged arc welded sections

The weld seam of submerged arc welded hollow sections shall be tested either in accordance with EN 10246-9 to acceptance level U4 or by radiography in accordance with EN 10246-10 with an image quality class R2.

Butt welds, used to join lengths of strip/plate together in the spiral submerged arc weld process, shall be permitted, provided that the butt weld is tested to the same type of procedure and meets the same acceptance level as the main weld seam.

9.5 Retests, sorting and reprocessing

For retests, sorting and reprocessing the requirements of EN 10021 shall apply.

10 Marking

10.1 Except as provided for in 10.2 for hollow sections which are bundled, each hollow section shall be marked by suitable and durable methods such as painting, stamping, adhesive labels or attached tags with the following:

- the steel designation, e.g. EN 10210-S275J0H;
- the manufacturer's name or trademark;
- in the case of specific inspection:
 - an identification number, e.g. order number, which permits the correlation of the product or delivery unit to the related document;

- the mark of the external inspection representative (where applicable).

10.2 Where the products are supplied bundled, the marking required in 10.1 shall be on a label, which shall be securely attached to the bundle.

11 Evaluation of conformity

Where evaluation of conformity is required for regulatory purposes Annex D shall apply.

Annex A (normative)

Structural hollow sections of non-alloy quality steels — Chemical composition and mechanical properties

Table A.1 — Chemical composition — Cast analysis for product thickness ≤ 120 mm

Steel grade		Type of deoxidation ^a	% by mass, maximum						
			C		Si	Mn	P	S	N ^{b c}
Steel name	Steel number	Specified thickness (mm)							
		≤ 40	$>40 \leq 120$						
S235JRH	1.0039	FN	0,17	0,20	—	1,40	0,040	0,040	0,009
S275J0H	1.0149	FN	0,20	0,22	—	1,50	0,035	0,035	0,009
S275J2H	1.0138	FF	0,20	0,22	—	1,50	0,030	0,030	—
S355J0H	1.0547	FN	0,22	0,22	0,55	1,60	0,035	0,035	0,009
S355J2H	1.0576	FF	0,22	0,22	0,55	1,60	0,030	0,030	—
S355K2H	1.0512	FF	0,22	0,22	0,55	1,60	0,030	0,030	—

^a The deoxidation methods are designated as follows:
 FN = Rimming steel not permitted
 FF = Fully killed steel containing nitrogen binding elements in amounts sufficient to bind available nitrogen (e.g. min. 0,020 % total Al, or 0,015 % soluble Al).

^b It is permissible to exceed the specified values provided that for each increase of 0,001 % N the P max. content is also reduced by 0,005 %. The N content of the cast analysis, however, shall not be more than 0,012 %.

^c The maximum value for nitrogen does not apply if the chemical composition shows a minimum total Al content of 0,020 % with a minimum Al/N ratio of 2:1, or if sufficient other N-binding elements are present. The N-binding elements shall be recorded in the Inspection Document.

Table A.2 — Maximum carbon equivalent value (CEV) based on cast analysis^a

Steel grade		Maximum CEV in % for specified thicknesses in mm			
Steel name	Steel number	≤ 16	> 16	> 40	> 65
			≤ 40	≤ 65	≤ 120
S235JRH	1.0039	0,37	0,39	0,41	0,44
S275J0H	1.0149	0,41	0,43	0,45	0,48
S275J2H	1.0138	0,41	0,43	0,45	0,48
S355J0H	1.0547	0,45	0,47	0,50	0,53
S355J2H	1.0576	0,45	0,47	0,50	0,53
S355K2H	1.0512	0,45	0,47	0,50	0,53

^a See 6.5.2, Option 1.2.

EN 10210-1:2006 (E)

Table A.3 — Mechanical properties of non-alloy structural steel hollow section

Steel grade		Minimum yield strength R_{eH} MPa						Tensile strength R_m MPa			Minimum elongation $A_{1.18}$ ^{a b} %			Minimum impact energy KV ^d J			
Steel name	Steel number	Specified thickness mm						Specified thickness mm			Specified thickness mm			At test temperature of			
		≤ 16	> 16 ≤ 40	> 40 ≤ 63	> 63 ≤ 80	> 80 ≤ 100	> 100 ≤ 120	≤ 3	> 3 ≤ 100	> 100 ≤ 120	≤ 40	> 40 ≤ 63	> 63 ≤ 100	-20 °C	0 °C	20 °C	
S235JRH ^c	1.0039	235	225	215	215	215	195	360-510	360-510	350-500	26	25	24	-	-	-	27
S275J0H ^c	1.0149																
S275J2H	1.0138	275	265	255	245	235	225	430-580	410-560	400-540	23	22	21	27	-	-	-
S355J0H ^c	1.0547																
S355J2H	1.0576	355	345	335	325	315	295	510-680	470-630	450-600	22	21	20	27	-	-	-
S355K2H	1.0512													40 °C	-	-	-

^a Longitudinal values. Transverse values are 2 % lower.

^b For thicknesses < 3 mm, see 9.2.2.

^c The impact properties are verified only when Option 1.3 is specified.

^d For impact properties for reduced section test pieces see 6.6.2.

^e This value corresponds to 27J at -30 °C (see EN 1993-1-1).

Annex B
(normative)

Structural hollow sections of fine grain steels — Chemical composition and mechanical properties

Table B.1 — Chemical composition — Cast analyses for product thickness ≤ 65 mm

Steel grade		Type of deoxidation ^a	Sub group ^b	% by mass													
Steel name	Steel number			C max.	Si max.	Mn	P max.	S max.	Nb max.	V max.	Al total ^c min.	Ti max.	Cr max.	Ni max.	Mo max.	Cu ^d max.	N max.
S275NH	1.0493	GF	QS	0,20	0,40	0,50 1,40	0,035 0,030	0,030 0,025	0,050	0,08	0,020	0,03	0,30	0,10	0,35	0,015	
S275NLH	1.0497																
S355NH	1.0539	GF	QS	0,20	0,50	0,90 1,65	0,035 0,030	0,030 0,025	0,050	0,12	0,020	0,03	0,50	0,10	0,35	0,020	
S355NLH	1.0549					0,18											
S420NH	1.8750	GF	SS	0,22	0,60	1,00 1,70	0,035 0,030	0,030 0,025	0,050	0,20	0,020	0,03	0,80	0,10	0,70	0,025	
S420NLH	1.8751																
S460NH	1.8953	GF	SS	0,22	0,60	1,00 1,70	0,035 0,030	0,030 0,025	0,050	0,20	0,020	0,03	0,80	0,10	0,70	0,025	
S460NLH	1.8956																

^a The deoxidation method is designated as follows:

GF = fully killed steel containing nitrogen binding elements in amounts sufficient to bind the available nitrogen and having a fine grain structure.

^b QS = quality steel. SS = special steel.

^c If sufficient N-binding elements are present, the minimum total Al content does not apply.

^d If the copper content is greater than 0,30 % then the nickel content shall be at least half of the copper content.

Table B.2 — Maximum carbon equivalent value based on cast analysis

Steel grade		Maximum CEV for specified thicknesses mm	
Steel name	Steel number	≤ 16	> 16 ≤ 65
S275NH	1.0493	0,40	0,40
S275NL	1.0497		
S355NH	1.0539	0,43	0,45
S335NLH	1.0549		
S420NH	1.8750	0,50	0,52
S420NLH	1.8751		
S460NH	1.8953	0,53	0,55
S460NLH	1.8956		

Table B.3 — Mechanical properties of fine grain structural steel hollow sections

Steel grade		Minimum yield strength R_{eH} MPa			Tensile strength R_m MPa at specified thickness ≤ 65 mm	Minimum elongation A % at specified thickness ≤ 65 mm		Minimum impact energy KV ^a J	
Steel name	Steel number	Specified thickness mm				Longitudinal	Transverse	At test temperature of	
		≤ 16	> 16 ≤ 40	> 40 ≤ 65				-50 °C	-20 °C
S275NH	1.0493	275	265	255	370–510	24	22	-	40 ^b
S275NLH	1.0497							27	-
S355NH	1.0539	355	345	335	470–630	22	20	-	40 ^b
S355NLH	1.0549							27	-
S420NH	1.8750	420	400	390	520–680	19	17	-	40 ^b
S420NLH	1.8751							27	-
S460NH	1.8953	460	440	430	540–720	17	15	-	40 ^b
S460NLH	1.8956							27	-

^a For impact properties for reduced section test pieces, see 6.6.2.

^b This value corresponds to 27J at -30 °C (see EN 1993-1-1).

Annex C (normative)

Location of samples and test pieces

Figures C.1 to C.3 give information on the location of samples and test pieces for hollow sections (see 8.2.2).

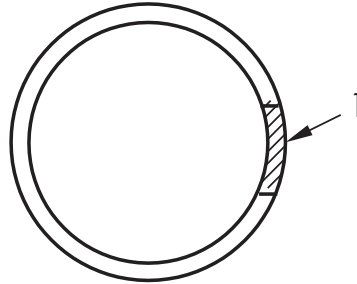

Key

- 1 At any point on circumference but in the case of welded sections remote from the weld

Figure C.1 — Circular and elliptical sections

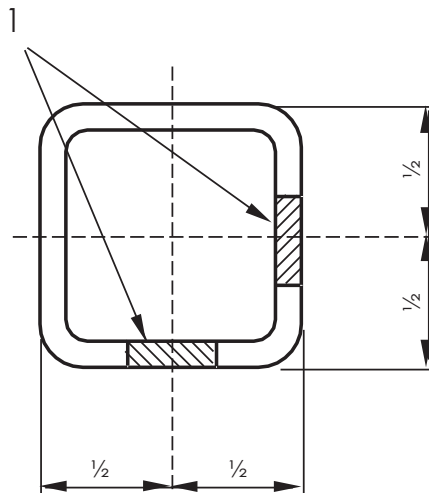

Key

- 1 Alternative positions (on any side except a side containing the weld in welded sections)

Figure C.2 — Square and rectangular sections – side

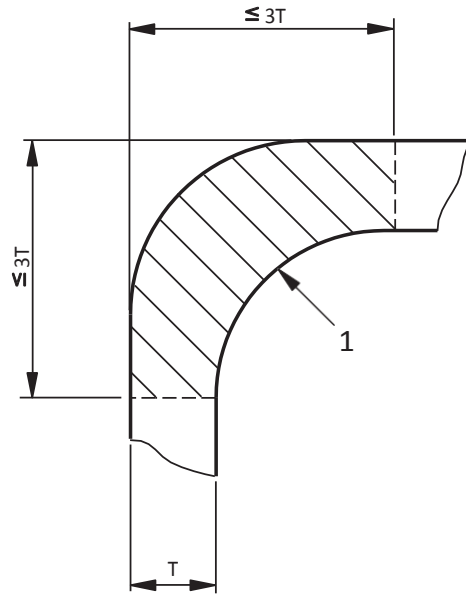
**Key**

1 Any corner region (except a corner containing the weld in welded sections) when Option 1.8 or 1.9 is specified.

Figure C.3 — Square and rectangular sections - corner region

Annex D (normative)

Evaluation of conformity

D.1 General

The conformity of steel hollow sections to the requirements of this standard and with the stated values (including classes) shall be demonstrated by:

- initial type testing
- factory production control by the manufacturer, including product assessment.

For the purposes of testing, steel hollow sections may be grouped into families, where it is considered that the selected property/properties is/are common to all steel hollow sections within that family.

D.2 Typetesting

D.2.1 Initial type testing

D.2.1.1 General

An initial type test is the complete set of tests, or other procedures, determining the performance characteristics of samples representative of the product types.

To show conformity with this standard initial type testing shall be performed on first use of this standard for steel hollow sections being put onto the market.

In addition, initial type testing shall be performed:

- at the beginning of the production of a new or modified steel hollow section design;
- if a change occurs in the feedstock;
- at the beginning of a new or modified method of production;

where this would change significantly one or more of the performance characteristics.

In cases where this would mean assessment of steel hollow sections for which type testing in accordance with this standard had already been performed, the testing frequency may be reduced:

- if it has been established that the performance characteristics have not been affected compared to the steel hollow sections already tested;
- if historical data is available (see D.2.1.3).

D.2.1.2 Characteristics

The assessment of the following performance characteristics is required:

- tolerances on dimensions and shape;
- elongation;
- tensile strength;
- yield strength;
- impact strength;
- weldability (chemical composition).

The following performance characteristics are not subject to initial type testing for the following reasons:

- release of dangerous substances - this may be assessed indirectly by controlling the content of the substance(s) concerned;
- bendability, cold/warm formability - the material is inherently ductile and therefore a specific test for these characteristics is not required;
- fatigue, fracture toughness/brittle strength – these characteristics are controlled by the method of use which is covered by EN 1993-1-1.

D.2.1.3 Use of historical data

Tests previously performed on the same steel hollow sections in accordance with the provisions of this standard (same performance characteristic(s), test method, sampling procedure, system of attestation of conformity, etc.) may be taken into account.

D.2.2 Sampling, testing and conformity criteria

D.2.2.1 Sampling

Initial type testing shall be performed on random samples of steel hollow sections representative of the types of steel hollow sections manufactured.

D.2.2.2 Testing and conformity criteria

The number of steel hollow sections to be tested (or assessed) shall be in accordance with Table D.1.

Table D.1 — Sampling and conformity criteria for type testing of steel hollow sections

Performance characteristic	Requirement clause	Assessment method	Number of tests/samples	Conformity criteria
tolerances on dimensions and shape	EN 10210-2:2006, Clause 6	EN 10210-2:2006, Clause 7	one per test unit (see 8.1.3 for definition of test unit)	6.10
elongation	6.6.1, Tables A.3 and B.3	9.2.2		6.6
tensile strength	6.6.1, Tables A.3 and B.3	9.2.2		6.6
yield strength	6.6.1, Tables A.3 and B.3	9.2.2		6.6
impact strength	6.6.2, Tables A.3 and B.3	9.2.3		6.6
weldability (chemical composition)	6.5, Tables A.2 and B.2 and 6.7.1	9.1		6.5

The results of all type tests shall be recorded and records retained by the manufacturer for at least 5 years.

D.3 Factory production control (FPC)

D.3.1 General

The manufacturer shall establish, document and maintain an FPC system to ensure that the products placed on the market conform to the declared performance characteristics. The FPC system shall consist of written procedures (works' manual), regular inspections and tests and/or assessments and the use of the results to control equipment, feedstock and other incoming material supply, the production process and the product. Records shall remain legible, readily identifiable and retrievable.

An FPC system conforming with the requirements of EN ISO 9001, and made specific to the product and the requirements of this standard, shall be considered to satisfy the above requirements.

The results of inspections, tests or assessments requiring action shall be recorded, as shall any corrective action taken. The action to be taken when control values or criteria are not met shall be recorded and retained for the period specified in the manufacturer's FPC procedures.

D.3.2 FPC requirements for all manufacturers

D.3.2.1 General

The manufacturer shall establish procedures to ensure that production tolerances allow for the performance characteristics of the steel hollow sections to be in conformity with the declared values derived from initial type testing.

The performance characteristics and the means of verification are:

- elongation, tensile strength and yield strength; tensile test in accordance with EN 10002-1;
- impact strength; impact test in accordance with EN 10045-1;
- weldability; chemical analysis in accordance with the methods listed in CR 10261.

The minimum frequency of testing shall be in accordance with Table D.1.

The manufacturer shall record the results of the tests specified above. These records shall as a minimum include the following information:

- identification of the steel hollow sections tested;
- the date of sampling and testing;
- the tests performed;
- the test results.

D.3.3 Manufacturer-specific FPC system requirements

D.3.3.1 Personnel

The responsibility, authority and the relationship between personnel that manages, performs or verifies work affecting product conformity, shall be defined. This applies in particular to personnel that needs to initiate actions preventing product non-conformities from occurring, actions in case of non-conformities and to identify and register product conformity problems. Personnel performing work affecting product conformity shall be competent on the basis of appropriate education, training, skills and experience for which records shall be maintained.

D.3.3.2 Equipment

All weighing, measuring and testing equipment necessary to achieve, or produce evidence of, conformity shall be calibrated or verified and regularly inspected according to documented procedures, frequencies and criteria. Control of monitoring and measuring devices shall comply with the appropriate clause of EN ISO 9001.

All equipment used in the manufacturing process shall be regularly inspected and maintained to ensure use, wear or failure does not cause inconsistency in the manufacturing process.

Inspections and maintenance shall be carried out and recorded in accordance with the manufacturer's written procedures and the records retained for the period defined in the manufacturer's FPC procedures.

D.3.3.3 Design process

The factory production control system shall document the various stages in the design of the steel hollow sections, and identify the checking procedure and those individuals responsible for all stages of design.

During the design process itself, a record shall be kept of all checks, their results, and any corrective actions taken. This record shall be sufficiently detailed and accurate to demonstrate that all stages of the design phase, and all checks, have been carried out satisfactorily. Compliance with EN ISO 9001:2000, 7.3 shall be deemed to satisfy the requirements of this clause.

D.3.3.4 Feedstock and incoming materials

The specifications of all incoming feedstock and materials shall be documented, as shall the inspection scheme for ensuring their conformity. The verification of conformity of the feedstock and incoming materials with their specification shall be in accordance with EN ISO 9001:2000, 7.4.3.

D.3.3.5 In-process control

The manufacturer shall plan and carry out production under controlled conditions. Compliance with EN ISO 9001:2000, 7.5.1 and 7.5.2 shall be deemed to satisfy the requirements of this clause.

D.3.3.6 Traceability and marking

Steel hollow sections shall be identifiable and traceable with regard to their production origin, see Clause 10. The manufacturer shall have written procedures ensuring that processes related to affixing traceability codes and/or markings, see Clause 10, are inspected regularly. Compliance with EN ISO 9001:2000, 7.5.3 shall be deemed to satisfy the requirements of this clause.

D.3.3.7 Non-conforming products

The manufacturer shall have written procedures which specify how non-conforming products shall be dealt with. Any such events shall be recorded as they occur and these records shall be kept for the period defined in the manufacturer's written procedures. Compliance with EN ISO 9001:2000, 8.3 shall be deemed to satisfy the requirements of this clause.

D.3.3.8 Corrective action

The manufacturer shall have documented procedures that instigate action to eliminate the cause of non-conformities in order to prevent recurrence. Compliance with EN ISO 9001:2000, 8.5.2 shall be deemed to satisfy the requirements of this clause.

D.3.3.9 Handling and storage

The manufacturer shall have written procedures stating methods of product handling and shall provide suitable storage areas to prevent damage or deterioration of the product.

Annex ZA (informative)

Clauses of this European Standard addressing the provisions of the EU Construction Products Directive

ZA.1 Scope and relevant characteristics

This European Standard has been prepared under a mandate M120 (Structural Metallic Products and ancillaries) given to CEN by the European Commission and the European Free Trade Association.

The clauses of this European Standard shown in this annex meet the requirements of the mandate given under the EU Construction Products Directive (89/106/EEC).

Compliance with these clauses confers a presumption of fitness of the construction products covered by this annex for the intended uses indicated herein; reference shall be made to the information accompanying the CE marking.

WARNING: Other requirements and other EU Directives, not affecting the fitness for intended use may be applicable to a construction product falling within the scope of this standard.

NOTE 1 In addition to any specific clauses relating to dangerous substances contained in this standard, there may be other requirements applicable to the products falling within its scope (e.g. transposed European legislation and national laws, regulations and administrative provisions). In order to meet the provisions of the EU Construction Products Directive, these requirements need also to be complied with, when and where they apply.

NOTE 2 *An informative database of European and national provisions on dangerous substances is available at the Construction web site on EUROPA (accessed through <http://europa.eu.int/comm/enterprise/construction/internal/dangsub/dangmain.htm>).*

This annex establishes the conditions for the CE marking of the structural hollow sections intended for the uses indicated in Table ZA.1 and shows the relevant clauses applicable.

The scope of this annex is defined by Table ZA.1

Table ZA.1 — Relevant clauses for product and intended use

Product:		Steel hollow sections	
Intended use:		To be used in metal structures or in composite metal and concrete structures	
Essential characteristic	Requirement clauses in this European Standard	Levels and/or classes	Notes
Tolerances on dimensions and shape.	EN 10210-2:2006, Clause 6	—	Pass/fail limits are specified in EN 10210-2:2006, Table 2
Elongation	6.6.1, Tables A.3 and B.3	—	% Values to be achieved are contained in Annexes A and B.
Tensile strength and yield strength	6.6.1, Tables A.3 and B.3	—	MPa Values to be achieved are contained in Annexes A and B.
Impact strength	6.6.2, Tables A.3 and B.3	—	J Values to be achieved are contained in Annexes A and B.
Weldability	6.5, Tables A.2 and B.2 and 6.7.1	—	CEV value specified. Tables are in Annexes A and B, formula for calculation is specified.
Durability ^a	6.7.2	—	By option to specify that the product is suitable for galvanizing.
^a Durability (against corrosion) is dependent on the method of protection and/or thickness of coating.			

The requirement on a certain characteristic is not applicable in those Member States (MSs) where there are no regulatory requirements on that characteristic for the intended use of the product. In this case, manufacturers placing their products on the market of these MSs are not obliged to determine nor declare the performance of their products with regard to this characteristic and the option “No performance determined” (NPD) in the information accompanying the CE marking (see Clause ZA.3) may be used. The NPD option may not be used, however, where the characteristic is subject to a threshold level.

ZA.2 Procedure for the attestation of conformity of steel hollow sections

ZA.2.1 System of attestation of conformity

The system of attestation of conformity of steel hollow sections indicated in Table ZA.1, in accordance with the Decision of the Commission (1998/214/EC) of 18 March 1998 as given in the Annex III of the mandate for Structural metallic products and ancillaries is shown in Table ZA.2 for the intended uses and relevant levels or classes.

Table ZA.2 — System of attestation of conformity

Product	Intended use	Level(s) or class(es)	Attestation of conformity system(s)
Steel hollow section	To be used in metal structures or in composite metal and concrete structures.	-	2+
System 2+: See Directive 89/106/EEC (CPD), Annex III.2. (ii), First possibility, including certification of the factory production control system by a notified body on the basis of its continuous surveillance, assessment and approval.			

The attestation of conformity of the steel hollow sections in Table ZA.1 shall be according to the evaluation of conformity procedures indicated in Table ZA.3 resulting from application of the clauses of this European Standard indicated therein.

Table ZA.3 — Assignment of conformity tasks for steel hollow sections under system 2+

Tasks		Content of task	Evaluation of conformity clauses to apply
Tasks under the responsibility of the manufacturer	Factory production control	All parameters related to all characteristics of Table ZA.1	Clause 11 D.3
	Initial type testing	All relevant characteristics of Table ZA.1	Clause 11 D.2
Tasks under the responsibility of the notified body	Certification of factory production control system on the basis of:	Initial inspection of factory and factory production control system	Clause 11 D.3
		Continuous surveillance, assessment and approval of factory production control system	

ZA.2.2 EC Certificate and declaration of conformity

The manufacturer or his agent established in the European Economic Area (EEA), shall prepare and retain a declaration of conformity, which authorises the affixing of the CE marking. This declaration shall include:

EN 10210-1:2006(E)

- name and address of the manufacturer, or his authorised representative established in the EEA, and the place of production;
- description of the product type (type, identification, use...), and a copy of the information accompanying the CE marking;
- provisions to which the product conforms (e.g. Annex ZA of this European Standard);
- particular conditions applicable to the use of the product (if necessary);
- the number of the accompanying factory production control system certificate;
- name of, and position held by, the person empowered to sign the declaration on behalf of the manufacturer or his authorised representative.

The declaration shall be accompanied by a factory production control system certificate, drawn up by a notified body, which shall contain in addition to the information above, the following

- name and address of the notified body;
- the number of the factory production control system certificate;
- conditions and period of validity of the certificate, where applicable;
- name of, and position held by, the person empowered to sign the certificate.

This declaration and certificate shall be presented in the official language or language(s) acceptable to the Member State in which the product is to be used.

ZA.3 CE Marking and labelling

The CE marking shall be in accordance with Directive 93/68/EEC²⁾ and be placed on the accompanying commercial documents or inspection document. The CE marking consists of the letters "CE" in the specified form and shall be accompanied by the following information.

- Identification number of the notified body;
- name or identifying mark of the producer;
- the last two digits of the year of marking;
- the number of the EC certificate of conformity and the name or number of the notified body with regard to the factory production control system;
- product designation (see 4.2);
- "No performance determined" for characteristics where this is relevant.

The "No performance determined" (NPD) option may not be used where the characteristic is subject to a threshold level. Otherwise, the NPD option may be used when and where the characteristic, for a given intended use, is not subject to regulatory requirements in the Member State of destination.

² Council Directive 93/68/EEC of July 1993 amending 12 Directives, including Directive 89/106/EEC harmonising the provisions for the CE marking.

Figure ZA.1 gives an example of the information to be given on the product, label, packaging and/or commercial documents.

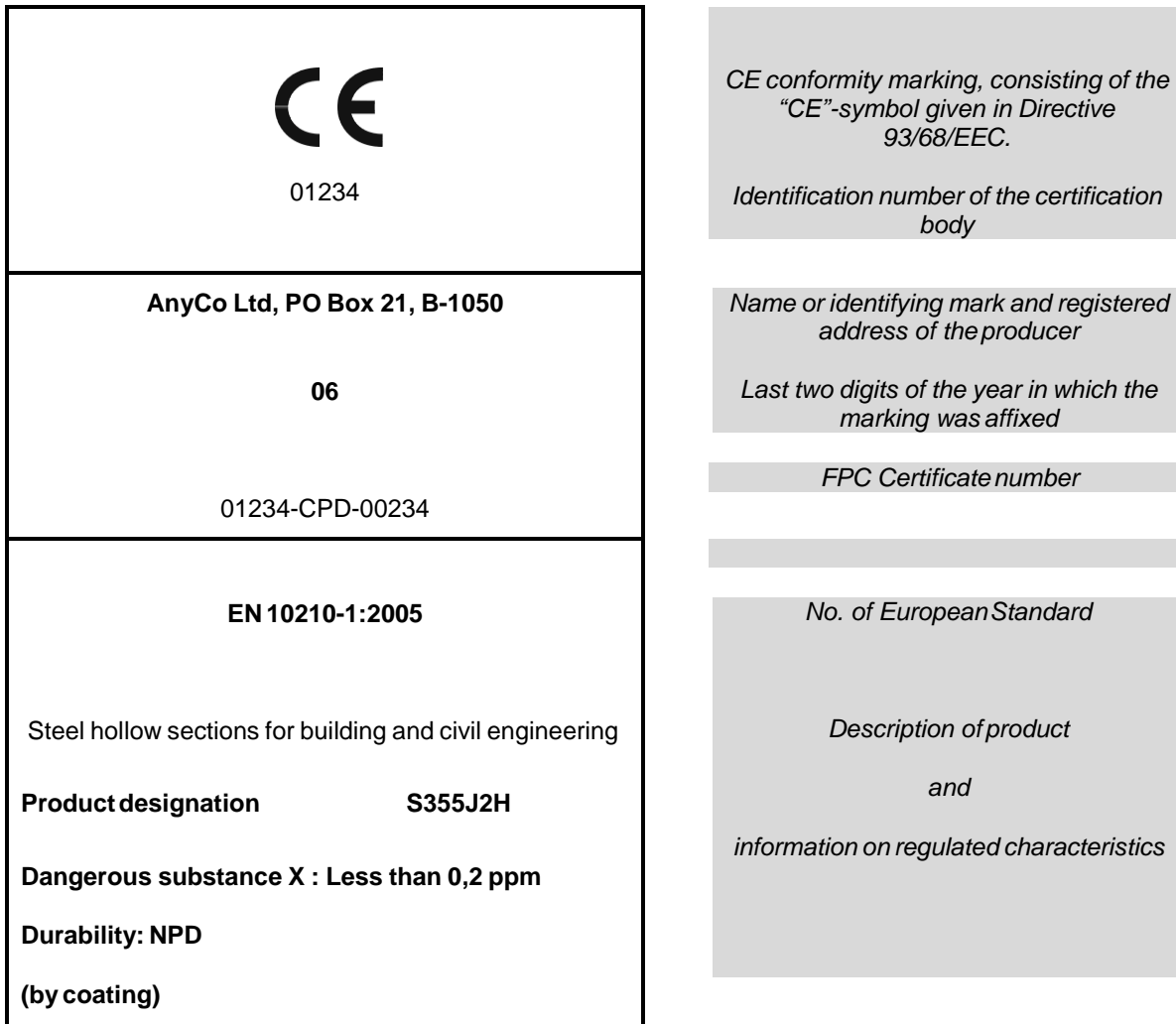

Figure ZA.1 – Example CE marking information

In addition to any specific information relating to dangerous substances shown above, the product should also be accompanied, when and where required and in the appropriate form, by documentation listing any other legislation on dangerous substances for which compliance is claimed, together with any information required by that legislation.

NOTE European legislation without national derogations need not be mentioned.

Bibliography

EN 473, *Non-destructive testing – Qualification and certification of NDT personnel – General principles*

EN 1011-1, *Welding — Recommendations for welding of metallic materials — Part 1: General guidance for arc welding*

EN 1011-2, *Welding — Recommendations for welding of metallic materials — Part 2: Arc welding of ferritic steels*

EN 1993-1-1, *Eurocode 3: Design of steel structures - Part 1-1: General rules and rules for buildings*

EN 10025-2, *Hot rolled products of structural steels — Part 2: Technical delivery conditions for non-alloy structural steels*

EN 10025-3, *Hot rolled products of structural steels — Part 3: Technical delivery conditions for normalized/normalized rolled weldable fine grain structural steels*

BSI — British Standards Institution

BSI is the independent national body responsible for preparing British Standards. It presents the UK view on standards in Europe and at the international level. It is incorporated by Royal Charter.

Revisions

British Standards are updated by amendment or revision. Users of British Standards should make sure that they possess the latest amendments or editions.

It is the constant aim of BSI to improve the quality of our products and services. We would be grateful if anyone finding an inaccuracy or ambiguity while using this British Standard would inform the Secretary of the technical committee responsible, the identity of which can be found on the inside front cover. Tel: +44 (0)20 8996 9000. Fax: +44 (0)20 8996 7400.

BSI offers members an individual updating service called PLUS which ensures that subscribers automatically receive the latest editions of standards.

Buying standards

Orders for all BSI, international and foreign standards publications should be addressed to Customer Services. Tel: +44 (0)20 8996 9001. Fax: +44 (0)20 8996 7001. Email: orders@bsi-global.com. Standards are also available from the BSI website at <http://www.bsi-global.com>.

In response to orders for international standards, it is BSI policy to supply the BSI implementation of those that have been published as British Standards, unless otherwise requested.

Information on standards

BSI provides a wide range of information on national, European and international standards through its Library and its Technical Help to Exporters Service. Various BSI electronic information services are also available which give details on all its products and services. Contact the Information Centre. Tel: +44 (0)20 8996 7111. Fax: +44 (0)20 8996 7048. Email: info@bsi-global.com.

Subscribing members of BSI are kept up to date with standards developments and receive substantial discounts on the purchase price of standards. For details of these and other benefits contact Membership Administration. Tel: +44 (0)20 8996 7002. Fax: +44 (0)20 8996 7001. Email: membership@bsi-global.com.

Information regarding online access to British Standards via British Standards Online can be found at <http://www.bsi-global.com/bsonline>.

Further information about BSI is available on the BSI website at <http://www.bsi-global.com>.

Copyright

Copyright subsists in all BSI publications. BSI also holds the copyright, in the UK, of the publications of the international standardization bodies. Except as permitted under the Copyright, Designs and Patents Act 1988 no extract may be reproduced, stored in a retrieval system or transmitted in any form or by any means – electronic, photocopying, recording or otherwise – without prior written permission from BSI.

This does not preclude the free use, in the course of implementing the standard, of necessary details such as symbols, and size, type or grade designations. If these details are to be used for any other purpose than implementation then the prior written permission of BSI must be obtained.

Details and advice can be obtained from the Copyright & Licensing Manager. Tel: +44 (0)20 8996 7070. Fax: +44 (0)20 8996 7553. Email: copyright@bsi-global.com.