



PED Certified | OHSAS 18001:2007 | ISO 9001 : 2008 | ISO 14001:2004 |
Govt. Recog. Export House.

**Manufacturer, Exporter, Stockiest, Supplier, Trader for
Carbon Steel, Stainless Steel, Alloy Steel for Seamless, Welded,
ERW, LSAW, DSAW, HSAW, HFI, EFW Pipes.**

Flat products made of steels for pressure purposes —

Part 2: Non-alloy and alloy steels with specified elevated temperature properties

The European Standard EN 10028-2:2003 has the status of a
British Standard

ICS 77.140.30; 77.140.50

National foreword

This British Standard is the official English language version of EN 10028-2:2003. It supersedes BS EN 10028-2:1993 which is withdrawn.

The UK participation in its preparation was entrusted to Technical Committee ISE/73/2, Steel plates and bars for pressure purposes, which has the responsibility to:

- aid enquirers to understand the text;
- present to the responsible international/European committee any enquiries on the interpretation, or proposals for change, and keep the UK interests informed;
- monitor related international and European developments and promulgate them in the UK.

A list of organizations represented on this committee can be obtained on request to its secretary.

Cross-references

The British Standards which implement international or European publications referred to in this document may be found in the *BSI Catalogue* under the section entitled “International Standards Correspondence Index”, or by using the “Search” facility of the *BSI Electronic Catalogue* or of British Standards Online.

This publication does not purport to include all the necessary provisions of a contract. Users are responsible for its correct application.

Compliance with a British Standard does not of itself confer immunity from legal obligations.

This British Standard, was published under the authority of the Standards Policy and Strategy Committee on 24 June 2003

Summary of pages

This document comprises a front cover, an inside front cover, the EN title page, pages 2 to 25 and a back cover.

The BSI copyright date displayed in this document indicates when the document was last issued.

Amendments issued since publication

Amd. No.	Date	Comments

© BSI 24 June 2003

ISBN 0 580 42145 7

English version

Flat products made of steels for pressure purposes - Part 2: Non-alloy and alloy steels with specified elevated temperature properties

Produits plats en aciers pour appareils à pression - Partie
2: Aciers non alliés et alliés avec caractéristiques
spécifiées à température élevée

Flacherzeugnisse aus Druckbehälterstählen - Teil 2:
Unlegierte und legierte Stähle mit festgelegten
Eigenschaften bei erhöhten Temperaturen

This European Standard was approved by CEN on 20 February 2003.

CEN members are bound to comply with the CEN/CENELEC Internal Regulations which stipulate the conditions for giving this European Standard the status of a national standard without any alteration. Up-to-date lists and bibliographical references concerning such national standards may be obtained on application to the Management Centre or to any CEN member.

This European Standard exists in three official versions (English, French, German). A version in any other language made by translation under the responsibility of a CEN member into its own language and notified to the Management Centre has the same status as the official versions.

CEN members are the national standards bodies of Austria, Belgium, Czech Republic, Denmark, Finland, France, Germany, Greece, Hungary, Iceland, Ireland, Italy, Luxembourg, Malta, Netherlands, Norway, Portugal, Slovakia, Spain, Sweden, Switzerland and United Kingdom.



EUROPEAN COMMITTEE FOR STANDARDIZATION
COMITÉ EUROPÉEN DE NORMALISATION
EUROPÄISCHES KOMITEE FÜR NORMUNG

Management Centre: rue de Stassart, 36 B-1050 Brussels

Contents

	Page
Foreword	3
1 Scope	4
2 Normative references	4
3 Terms and definitions.....	4
4 Dimensions and tolerances on dimensions	4
5 Calculation of mass	4
6 Classification and designation.....	4
6.1 Classification.....	4
6.2 Designation	4
7 Information to be supplied by the purchaser.....	5
7.1 Mandatory information	5
7.2 Options	5
7.3 Example for ordering.....	5
8 Requirements	6
8.1 Steelmaking process	6
8.2 Delivery condition.....	6
8.3 Chemical composition.....	6
8.4 Mechanical properties	8
8.5 Surface condition.....	9
8.6 Internal soundness	9
8.7 Resistance to hydrogen induced cracking	9
8.8 Embrittlement of CrMo steels.....	9
9 Inspection	9
9.1 Types of inspection and inspection documents	9
9.2 Tests to be carried out	9
9.3 Retests	9
10 Sampling.....	9
11 Test methods.....	10
12 Marking	10
Annex A (informative) Guidelines for heat treatment	15
Annex B (informative) Critical time temperature parameter $P_{crit.}$ and possible combinations of stress relieving temperature and holding time	16
Annex C (informative) Reference data of strength for 1 % (plastic) creep strain and creep rupture	17
Annex D (normative) Evaluation of resistance to hydrogen induced cracking	22
Annex E (normative) Step cooling test	23
Annex ZA (informative) Clauses of this European Standard addressing essential requirements or other provisions of EU Directives	24
Bibliography	25

Foreword

This document (EN 10028-2:2003) has been prepared by Technical Committee ECISS /TC 22, "Steels for pressure purposes - Qualities" the secretariat of which is held by DIN.

This European Standard shall be given the status of a national standard, either by publication of an identical text or by endorsement, at the latest by December 2003, and conflicting national standards shall be withdrawn at the latest by December 2003.

This document supersedes EN 10028-2:1992.

This document has been prepared under a mandate given to CEN by the European Commission and the European Free Trade Association, and supports essential requirements of EU Directive(s).

For relationship with EU Directive(s), see informative annex ZA, which is an integral part of this document.

This European Standard consists of the following parts, under the general title *Flat products made of steels for pressure purposes*:

Part 1: General requirements

Part 2: Non-alloy and alloy steels with specified elevated temperature properties

Part 3: Weldable fine grain steels, normalized

Part 4: Nickel alloy steels with specified low temperature properties

Part 5: Weldable fine grain steels, thermomechanically rolled

Part 6: Weldable fine grain steels, quenched and tempered

Part 7: Stainless steels

NOTE The clauses marked by two points () contain information relating to agreements that may be made at the time of enquiry and order.

Annexes A, B, C are for information only. Annexes D and E are normative.

This document includes a bibliography.

According to the CEN/CENELEC Internal Regulations, the national standards organizations of the following countries are bound to implement this European Standard: Austria, Belgium, Czech Republic, Denmark, Finland, France, Germany, Greece, Hungary, Iceland, Ireland, Italy, Luxembourg, Malta, Netherlands, Norway, Portugal, Slovakia, Spain, Sweden, Switzerland and the United Kingdom.

1 Scope

This European Standard specifies requirements for flat products for pressure equipment made of weldable non-alloy and alloy steels with elevated temperature properties as specified in Table 1.

The requirements and definitions of EN 10028-1 also apply.

2 Normative references

This European Standard incorporates by dated or undated reference, provisions from other publications. These normative references are cited at the appropriate places in the text, and the publications are listed hereafter. For dated references, subsequent amendments to or revisions of any of these publications apply to this European Standard only when incorporated in it by amendment or revision. For undated references the latest edition of the publication referred to applies (including amendments).

EN 10028-1:2000 + A1:2002, *Flat products made of steels for pressure purposes – Part 1: General requirements*.

EN 10204, *Metallic products – Types of inspection documents*.

EN 10229, *Evaluation of resistance of steel products to hydrogen induced cracking (HIC)*.

3 Terms and definitions

For the purposes of this European Standard the terms and definitions given in EN 10028-1 apply.

4 Dimensions and tolerances on dimensions

See EN 10028-1.

5 Calculation of mass

See EN 10028-1.

6 Classification and designation

6.1 Classification

In accordance with EN 10020, the grades P235GH, P265GH, P295GH and P355GH are non-alloy quality steels. All other grades are alloy special steels.

6.2 Designation

See EN 10028-1.

7 Information to be supplied by the purchaser

7.1 Mandatory information

See EN 10028-1.

7.2 Options

A number of options are specified in this standard and listed below. Additionally the relevant options of EN 10028-1 apply. If the purchaser does not indicate a wish to implement any of these options at the time of enquiry and order, the products shall be supplied in accordance with the basic specification (see also EN 10028-1).

- a) lower copper content and maximum tin content (see Table 1, footnote b);
- b) minimum chromium content of 0,80% (see Table 1, footnote f);
- c) maximum carbon content of 0,17% for product thicknesses greater than 150 mm (see Table 1, footnote g);
- d) tests in the simulated normalized condition (see 8.2.2);
- e) delivery conditions deviating from those specified in Table 3 (see 8.2.2 and 8.2.3);
- f) maximum carbon equivalent value for P235GH, P265GH, P295GH and P355GH (see 8.3.3);
- g) HIC test in accordance with EN 10229 (see 8.7);
- h) step cooling test in accordance with annex E (see 8.8);
- i) mid thickness test pieces for the impact test (see clause 10);
- j) mechanical properties for product thicknesses > 250 mm (see Table 3, footnote a);
- k) specification of the delivery condition +QT where the usual delivery condition is +NT (see Table 3, footnote c and Table 4, footnote c);
- l) additional impact energy values (see Table 3, footnote f);
- m) $R_{p0,2}$ values at elevated temperature for increased product thicknesses (see Table 4, footnote b).

7.3 Example for ordering

10 plates with nominal dimensions, thickness = 50 mm, width = 2 000 mm, length = 10 000 mm, made of a steel grade with the name 16Mo3 and the number 1.5415 as specified in EN 10028-2, to be delivered untreated, inspection document 3.1.B as specified in EN 10204:

10 plates – 50 x 2 000 x 10 000 – EN 10028-2 16Mo3+AR - Inspection document 3.1.B

or

10 plates – 50 x 2 000 x 10 000 – EN 10028-2 1.5415+AR – Inspection document 3.1.B

8 Requirements

8.1 Steelmaking process

See EN 10028-1.

8.2 Delivery condition

8.2.1 Unless otherwise agreed at the time of enquiry and order, the products covered by this standard shall be supplied in the usual conditions given in Table 3 (see 8.2.3).

8.2.2 Normalizing may, at the discretion of manufacturer, be replaced with normalizing rolling for the steel grades P235GH, P265GH, P295GH and P355GH. In this case, tests in the simulated normalized condition with an agreed frequency of testing may be agreed at the time of enquiry and order to verify that the specified properties are complied with.

8.2.3 If so agreed at the time of enquiry and order, products made of steel grades P235GH, P265GH, P295GH, P355GH and 16Mo3 may also be delivered in the untreated condition. Products made of one of the other alloy grades may be supplied in the tempered or normalized condition or, in exceptional cases, in the untreated condition if so agreed (Annex A contains heat treatment information for the purchaser).

In these cases, testing shall be carried out on test pieces in the usual delivery condition as indicated in Table 3.

NOTE The testing of the test pieces in a simulated heat treated condition does not discharge the processor from the obligation of providing proof of the specified properties in the finished product.

8.2.4 Information on welding is given in EN 1011-1 and EN 1011-2.

NOTE Excessive post weld heat treatment (PWHT) conditions can decrease the mechanical properties. When in stress relieving the intended time temperature parameter

$$P = T_s (20 + \lg t) \cdot 10^{-3},$$

where

T_s is the stress relieving temperature in K and

t is the holding time in hours,

is exceeding the critical ($P_{crit.}$) values in annex B, the purchaser should in his enquiry and order inform the manufacturer accordingly and, where appropriate, tests on simulated heat treated samples can be agreed to check whether after such a treatment the properties specified in this European Standard can still be regarded as valid.

8.3 Chemical composition

8.3.1 The requirements of Table 1 shall apply for the chemical composition according to the cast analysis.

8.3.2 The product analysis shall not deviate from the specified values for the cast analysis as specified in Table 1 by more than the values given in Table 2.

8.3.3 A maximum value for the carbon equivalent may be agreed upon at the time of enquiry and order for steel grades P235GH, P265GH, P295GH and P355GH. In this case, the following formula shall apply for calculation of the carbon equivalent value (CEV):

$$CEV = C + \frac{Mn}{6} + \frac{Cr + Mo + V}{5} + \frac{Ni + Cu}{15}$$

Table 1 — Chemical composition (cast analysis) ^a

Steel grade		% by mass														Others
name	number	C	Si	Mn	P	S	Al _{total}	N	Cr	Cu ^b	Mo	Nb	Ni	Ti	V	Others
P235GH	1.0345	0,16	0,35	0,60 ^c to 1,20	0,025	0,015	0,020	0,012 ^d	0,30	0,30	0,08	0,020	0,30	0,03	0,02	
P265GH	1.0425	0,20	0,40	0,80 ^e to 1,40	0,025	0,015	0,020	0,012 ^d	0,30	0,30	0,08	0,020	0,30	0,03	0,02	
P295GH	1.0481	0,08 to 0,20	0,40	0,90 ^e to 1,50	0,025	0,015	0,020	0,012 ^d	0,30	0,30	0,08	0,020	0,30	0,03	0,02	Cr+Cu+Mo+
P355GH	1.0473	0,10 to 0,22	0,60	1,10 to 1,70	0,025	0,015	0,020	0,012 ^d	0,30	0,30	0,08	0,020	0,30	0,03	0,02	Ni: 0,70
16Mo3	1.5415	0,12 to 0,20	0,35	0,40 to 0,90	0,025	0,010	^e	0,012	0,30	0,30	0,25 to 0,35	-	0,30	-	-	-
18MnMo4-5	1.5414	0,20	0,40	0,90 to 1,50	0,015	0,005	^e	0,012	0,30	0,30	0,45 to 0,60	-	0,30	-	-	-
20MnMoNi4-5	1.6311	0,15 to 0,23	0,40	1,00 to 1,50	0,020	0,010	^e	0,012	0,20	0,20	0,45 to 0,60	-	0,40 to 0,80	-	0,02	-
15NiCuMoNb5-6-4	1.6368	0,17	0,25 to 0,50	0,80 to 1,20	0,025	0,010	0,015	0,020	0,30	0,50 to 0,80	0,25 to 0,50	0,015 to 0,045	1,00 to 1,30	-	-	-
13CrMo4-5	1.7335	0,08 to 0,18	0,35	0,40 to 1,00	0,025	0,010	^e	0,012	0,70 ^f to 1,15	0,30	0,40 to 0,60	-	-	-	-	-
13CrMoSi5-5	1.7336	0,17	0,50 to 0,80	0,40 to 0,65	0,015	0,005	^e	0,012	1,00 to 1,50	0,30	0,45 to 0,65	-	0,30	-	-	-
10CrMo9-10	1.7380	0,08 to 0,14 ^g	0,50	0,40 to 0,80	0,020	0,010	^e	0,012	2,00 to 2,50	0,30	0,90 to 1,10	-	-	-	-	-
12CrMo9-10	1.7375	0,10 to 0,15	0,30	0,30 to 0,80	0,015	0,010	0,010 to 0,040	0,012	2,00 to 2,50	0,25	0,90 to 1,10	-	0,30	-	-	-
X12CrMo5	1.7362	0,10 to 0,15	0,50	0,30 to 0,60	0,020	0,005	^e	0,012	4,00 to 6,00	0,30	0,45 to 0,65	-	0,30	-	-	-
13CrMoV9-10	1.7703	0,11 to 0,15	0,10	0,30 to 0,60	0,015	0,005	^e	0,012	2,00 to 2,50	0,20	0,90 to 1,10	0,07	0,25	0,03	0,25 to 0,35	0,002 B 0,015Ca
12CrMoV12-10	1.7767	0,10 to 0,15	0,15	0,30 to 0,60	0,015	0,005	^e	0,012	2,75 to 3,25	0,25	0,90 to 1,10	0,07 ^h	0,25	0,03 ^h	0,20 to 0,30	0,003B ^h 0,015Ca ^h
X10CrMoVNB9-1	1.4903	0,08 to 0,12	0,50	0,30 to 0,60	0,020	0,005	0,040	0,030 to 0,070	8,00 to 9,50	0,30	0,85 to 1,05	0,06 to 0,10	0,30	-	0,18 to 0,25	-

^a Elements not listed in this table shall not be intentionally added to the steel without the agreement of the purchaser except for finishing the cast. All appropriate measures shall be taken to prevent the addition from scrap or other materials used in steelmaking of these elements which may affect the mechanical properties and usability.

^b A lower maximum copper content and/or a maximum sum of copper and tin content, e.g. Cu + 6 Sn 0,33%, may be agreed upon at the time of enquiry and order, e.g. with regard to hot formability for the grades where only a maximum copper content is specified.

^c For product thicknesses < 6 mm, a minimum manganese content of 0,20 % lower than specified is permitted.

^d A ratio $\frac{Al}{N}$ 2 shall apply.

^e The Al content of the cast shall be determined and given in the inspection document.

^f If resistance to pressurized hydrogen is of importance, a minimum content of 0,80% Cr may be agreed upon at the time of enquiry and order.

^g For product thicknesses greater than 150 mm, a maximum content of 0,17% C may be agreed upon at the time of enquiry and order.

^h This grade may be produced with additions of either Ti + B or Nb + Ca. The following minimum contents shall apply: 0,015 % Ti and 0,001 % B in the case of additions of Ti + B, 0,015 % Nb and 0,0005 % Ca in the case of additions of Nb + Ca.

Table 2 — Permissible product analysis tolerances on the limiting values given in Table 1 for the cast analysis

Element	Specified value in the cast analysis according to Table 1	Permissible deviation ^a of the product analysis
	% by mass	% by mass
C	≤ 0,23	0,02
Si	≤ 0,35	0,05
	> 0,35 to ≤ 1,00	0,06
Mn	≤ 1,00	0,05
	> 1,00 to ≤ 1,70	0,10
P	≤ 0,015	+ 0,003
	> 0,015 to ≤ 0,025	+ 0,005
S	≤ 0,015	+ 0,003
Al	≥ 0,010	0,005
B	0,003	±0,0005
N	0,020	+ 0,002
	> 0,020 to 0,070	0,005
Cr	2,00	0,05
	> 2,00 to 10,00	0,10
Cu	≤ 0,30	0,05
	> 0,30 to 0,80	0,10
Mo	0,35	0,03
	> 0,35 to 1,10	+ 0,04
Nb	≤ 0,10	0,01
Ni	≤ 0,30	+ 0,05
	> 0,30 to 1,30	0,10
Cr+Cu+Mo+Ni	0,70	+ 0,05
Ti	≤ 0,03	0,01
V	≤ 0,05	0,01
	> 0,05 to 0,30	±0,03

^a If several product analyses are carried out on one cast, and the contents of an individual element determined lie outside the permissible range of the chemical composition specified for the cast analysis then it is only allowed to exceed the permissible maximum value or fall short of the permissible minimum value, but not both for one cast.

8.4 Mechanical properties

8.4.1 The values given in Tables 3 and 4 (see also EN 10028-1 and clause 10) shall apply.

8.4.2 Annex C gives mean values as preliminary data for the purchaser about 1% (plastic) creep strain and creep rupture.

8.5 Surface condition

See EN 10028-1.

8.6 Internal soundness

See EN 10028-1.

For possible verification of internal soundness, see also EN 10028-1.

8.7 Resistance to hydrogen induced cracking

Carbon and low alloy steels may be susceptible to cracking when exposed to corrosive H₂S containing environments, usually referred to as 'sour service'.

A test to evaluate the resistance to hydrogen induced cracking in accordance with annex D may be specified at the time of enquiry and order.

8.8 Embrittlement of CrMo steels

CrMo steels may tend to become brittle in service at temperatures between approximately 400 °C and 500 °C. This possible tendency for embrittlement can be simulated in the laboratory with the so called step cooling test. In this test a specimen is exposed to a temperature - time cycle as given in Figure E.1. The shift of a transition curve before and after the step cooling test is a measure for the embrittlement.

A step cooling test in accordance with annex E may be specified at the time of enquiry and order.

9 Inspection

9.1 Types of inspection and inspection documents

See EN 10028-1.

9.2 Tests to be carried out

See EN 10028-1 and 8.7 and 8.8.

9.3 Retests

See EN 10028-1.

10 Sampling

See EN 10028-1.

For the impact test, deviating from EN 10028-1:2000 + A1:2002, Figure 2, footnote f, the preparation of test pieces taken from the mid thickness may be agreed at the time of enquiry and order. In this case, test temperatures and minimum impact energy values shall also be agreed.

11 Test methods

See EN 10028-1, and annexes D and E.

12 Marking

See EN 10028-1.

Table 3 — Mechanical properties (applicable to the transverse direction)^a

Steel grade		Usual delivery condition ^{b,c}	Product thickness <i>t</i>	Tensile properties at room temperature			Impact energy KV J min. at a temperature in °C of		
				Yield strength <i>R_{eH}</i>	Tensile strength <i>R_m</i>	Elongation after fracture <i>A</i>	- 20	0	+ 20
name	number		mm	MPa min.	MPa	% min.			
P235GH	1.0345	+N ^d	16	235	360 to 480	24	27	34	40
			16 < <i>t</i> 40	225					
			40 < <i>t</i> 60	215					
			60 < <i>t</i> 100	200					
			100 < <i>t</i> 150	185	350 to 480				
150 < <i>t</i> 250	170	340 to 480							
P265GH	1.0425	+N ^d	16	265	410 to 530	22	27	34	40
			16 < <i>t</i> 40	255					
			40 < <i>t</i> 60	245					
			60 < <i>t</i> 100	215					
			100 < <i>t</i> 150	200	400 to 530				
150 < <i>t</i> 250	185	390 to 530							
P295GH	1.0481	+N ^d	16	295	460 to 580	21	27	34	40
			16 < <i>t</i> 40	290					
			40 < <i>t</i> 60	285					
			60 < <i>t</i> 100	260					
			100 < <i>t</i> 150	235	440 to 570				
150 < <i>t</i> 250	220	430 to 570							
P355GH	1.0473	+N ^d	16	355	510 to 650	20	27	34	40
			16 < <i>t</i> 40	345					
			40 < <i>t</i> 60	335					
			60 < <i>t</i> 100	315	490 to 630				
			100 < <i>t</i> 150	295	480 to 630				
150 < <i>t</i> 250	280	470 to 630							
16Mo3	1.5415	+N ^e	16	275	440 to 590	22	f	f	31
			16 < <i>t</i> 40	270					
			40 < <i>t</i> 60	260					
			60 < <i>t</i> 100	240	430 to 560				
			100 < <i>t</i> 150	220	420 to 570				
150 < <i>t</i> 250	210	410 to 570							
18MnMo4-5	1.5414	+NT	60	345	510 to 650	20	27	34	40
		+QT	60 < <i>t</i> 150	325					
			150 < <i>t</i> 250	310	480 to 620				
20MnMoNi4-5	1.6311	+QT	40	470	590 to 730	18	27	40	50
			40 < <i>t</i> 60	460					
			60 < <i>t</i> 100	450					
			100 < <i>t</i> 150	440					
			150 < <i>t</i> 250	400	560 to 700				
15NiCuMoNb 5-6-4	1.6368	+NT	40	460	610 to 780	16	27	34	40
			40 < <i>t</i> 60	440					
		+NT or +QT	60 < <i>t</i> 100	430	600 to 760				
		+QT	100 < <i>t</i> 150	420	590 to 740				
			150 < <i>t</i> 200	410	580 to 740				

Table 3 (concluded)

Steel grade		Usual delivery condition ^{b,c}	Product thickness t mm	Tensile properties at room temperature			Impact energy KV J min. at a temperature in °C of		
				Yield strength R_{eH} MPa min.	Tensile strength R_m MPa	Elongation after fracture A % min.	-20	0	+20
13CrMo4-5	1.7335	+NT	16	300	450 to 600	19	f	f	31
			16 < t 60	290			f	f	27
			60 < t 100	270	440 to 590		f	f	f
		+NT or +QT	100 < t 150	255	430 to 580				
		+QT	150 < t 250	245	420 to 570				
13CrMoSi5-5	1.7336	+NT	60	310	510 to 690	20	f	27	34
			60 < t 100	300			480 to 660		
		+QT	60	400	510 to 690		27	34	40
			60 < t 100	390	500 to 680				
		+QT	100 < t 250	380	490 to 670				
10CrMo9-10	1.7380	+NT	16	310	480 to 630	18	f	f	31
			16 < t 40	300			f	f	27
			40 < t 60	290	470 to 620				
		+NT or +QT	60 < t 100	280	460 to 610		17	f	f
		+QT	100 < t 150	260	450 to 600				
			150 < t 250	250					
12CrMo9-10	1.7375	+ NT or +QT	250	355	540 to 690	18	27	40	70
X12CrMo5	1.7362	+NT	60	320	510 to 690	20	27	34	40
			60 < t 150	300	480 to 660				
		+QT	150 < t 250	300	450 to 630				
13CrMoV9-10	1.7703	+ NT	60	455	600 to 780	18	27	34	40
			60 < t 150	435	590 to 770				
		+ QT	150 < t 250	415	580 to 760				
12CrMoV12-10	1.7767	+NT	60	455	600 to 780	18	27	34	40
			60 < t 150	435	590 to 770				
		+QT	150 < t 250	415	580 to 760				
X10CrMoVNb 9-1	1.4903	+NT	60	445	580 to 760	18	27	34	40
			60 < t 150	435	550 to 730				
		+QT	150 < t 250	435	520 to 700				

^a For product thicknesses > 250 mm (except for grades 12CrMo9-10 and 15NiCuMoNb5-6-4) property values may be agreed.

^b +N = normalized; +NT = normalized and tempered; +QT = quenched and tempered

^c For product thicknesses, where the usual delivery condition is +NT, higher strength and impact energy values may be agreed for the delivery condition +QT.

^d See 8.2.2.

^e This steel may also be supplied in the +NT condition at the discretion of the manufacturer.

^f A value may be agreed at the time of enquiry and order.

Table 4 — Minimum values for the 0,2% proof strength at elevated temperatures ^a

Steel grade		Product thickness ^{b,c} <i>t</i> mm	Minimum 0,2 % proof strength $R_{p0.2}$ MPa at a temperature in °C of									
name	number		50	100	150	200	250	300	350	400	450	500
P235GH ^d	1.0345	16	227	214	198	182	167	153	142	133	-	-
		16 < <i>t</i> 40	218	205	190	174	160	147	136	128	-	-
		40 < <i>t</i> 60	208	196	181	167	153	140	130	122	-	-
		60 < <i>t</i> 100	193	182	169	155	142	130	121	114	-	-
		100 < <i>t</i> 150	179	168	156	143	131	121	112	105	-	-
		150 < <i>t</i> 250	164	155	143	132	121	111	103	97	-	-
P265GH ^d	1.0425	16	256	241	223	205	188	173	160	150	-	-
		16 < <i>t</i> 40	247	232	215	197	181	166	154	145	-	-
		40 < <i>t</i> 60	237	223	206	190	174	160	148	139	-	-
		60 < <i>t</i> 100	208	196	181	167	153	140	130	122	-	-
		100 < <i>t</i> 150	193	182	169	155	142	130	121	114	-	-
		150 < <i>t</i> 250	179	168	156	143	131	121	112	105	-	-
P295GH ^d	1.0481	16	285	268	249	228	209	192	178	167	-	-
		16 < <i>t</i> 40	280	264	244	225	206	189	175	165	-	-
		40 < <i>t</i> 60	276	259	240	221	202	186	172	162	-	-
		60 < <i>t</i> 100	251	237	219	201	184	170	157	148	-	-
		100 < <i>t</i> 150	227	214	198	182	167	153	142	133	-	-
		150 < <i>t</i> 250	213	200	185	170	156	144	133	125	-	-
P355GH ^d	1.0473	16	343	323	299	275	252	232	214	202	-	-
		16 < <i>t</i> 40	334	314	291	267	245	225	208	196	-	-
		40 < <i>t</i> 60	324	305	282	259	238	219	202	190	-	-
		60 < <i>t</i> 100	305	287	265	244	224	206	190	179	-	-
		100 < <i>t</i> 150	285	268	249	228	209	192	178	167	-	-
		150 < <i>t</i> 250	271	255	236	217	199	183	169	159	-	-
16Mo3	1.5415	< 16	273	264	250	233	213	194	175	159	147	141
		16 < <i>t</i> 40	268	259	245	228	209	190	172	156	145	139
		40 < <i>t</i> 60	258	250	236	220	202	183	165	150	139	134
		60 < <i>t</i> 100	238	230	218	203	186	169	153	139	129	123
		100 < <i>t</i> 150	218	211	200	186	171	155	140	127	118	113
		150 < <i>t</i> 250	208	202	191	178	163	148	134	121	113	108
18MnMo4-5 ^e	1.5414	60	330	320	315	310	295	285	265	235	215	-
		60 < <i>t</i> 150	320	310	305	300	285	275	255	225	205	-
		150 < <i>t</i> 250	310	300	295	290	275	265	245	220	200	-

Table 4 (continued)

Steel grade		Product thickness ^{b, c} <i>t</i> mm	Minimum 0,2 % proof strength $R_{p0,2}$ MPa at a temperature in °C of									
name	number		50	100	150	200	250	300	350	400	450	500
20MnMoNi4-5	1.6311		< 40	460	448	439	432	424	415	402	384	-
		40 < <i>t</i> 60	450	438	430	423	415	406	394	375	-	-
		60 < <i>t</i> 100	441	429	420	413	406	398	385	367	-	-
		100 < <i>t</i> 150	431	419	411	404	397	389	377	359	-	-
		150 < <i>t</i> 250	392	381	374	367	361	353	342	327	-	-
15NiCuMoNb5-6-4	1.6368	< 40	447	429	415	403	391	380	366	351	331	-
		40 < <i>t</i> 60	427	410	397	385	374	363	350	335	317	-
		60 < <i>t</i> 100	418	401	388	377	366	355	342	328	309	-
		100 < <i>t</i> 150	408	392	379	368	357	347	335	320	302	-
		150 < <i>t</i> 200	398	382	370	359	349	338	327	313	295	-
13CrMo4-5	1.7335	< 16	294	285	269	252	234	216	200	186	175	164
		16 < <i>t</i> 60	285	275	260	243	226	209	194	180	169	159
		60 < <i>t</i> 100	265	256	242	227	210	195	180	168	157	148
		100 < <i>t</i> 150	250	242	229	214	199	184	170	159	148	139
		150 < <i>t</i> 250	235	223	215	211	199	184	170	159	148	139
13CrMoSi5-5+NT	1.7336+NT	< 60	299	283	268	255	244	233	223	218	206	-
		60 < <i>t</i> 100	289	274	260	247	236	225	216	211	199	-
13CrMoSi5-5+QT	1.7336+QT	60 < <i>t</i> 100	384	364	352	344	339	335	330	322	309	-
		100 < <i>t</i> 150	375	355	343	335	330	327	322	314	301	-
		150 < <i>t</i> 250	365	346	334	326	322	318	314	306	293	-
10CrMo9-10	1.7380	< 16	288	266	254	248	243	236	225	212	197	185
		16 < <i>t</i> 40	279	257	246	240	235	228	218	205	191	179
		40 < <i>t</i> 60	270	249	238	232	227	221	211	198	185	173
		60 < <i>t</i> 100	260	240	230	224	220	213	204	191	178	167
		100 < <i>t</i> 150	250	237	228	222	219	213	204	191	178	167
		150 < <i>t</i> 250	240	227	219	213	210	208	204	191	178	167
12CrMo9-10	1.7375	250	341	323	311	303	298	295	292	287	279	-
X12CrMo5	1.7362	60	310	299	295	294	293	291	285	273	253	222
		60 < <i>t</i> 250	290	281	277	275	275	273	267	256	237	208
13CrMoV9-10 ^e	1.7703	60	410	395	380	375	370	365	362	360	350	-
		60 < <i>t</i> 250	405	390	370	365	360	355	352	350	340	-
12CrMoV12-10 ^e	1.7767	60	410	395	380	375	370	365	362	360	350	-
		60 < <i>t</i> 250	405	390	370	365	360	355	352	350	340	-
X10CrMoVNb9-1	1.4903	60	432	415	401	392	385	379	373	364	349	324
		60 < <i>t</i> 250	423	406	392	383	376	371	365	356	341	316

^a The values correspond to the lower band of the relevant trend curve determined in accordance with EN 10314 with a confidence limit of about 98 % (2 s).

^b For product thicknesses exceeding the specified maximum thicknesses, $R_{p0,2}$ values at elevated temperatures may be agreed.

^c Delivery condition as given in Table 3 (but see footnote c to Table 3).

^d The values are reflecting the minimum values for furnace normalized test pieces.

^e $R_{p0,2}$ not determined in accordance with EN 10314. They are minimum values of the scatter band considered until now.

Annex A (informative)

Guidelines for heat treatment

Table A.1 gives reference data for heat treatment temperatures. For stress relief annealing see annex B.

Table A.1 — Guidelines on the temperatures for heat treatment

Steel grade		Temperature, °C		
name	number	Normalizing	Austenitizing	Tempering ^b
P235GH	1.0345	890 to 950 ^a	-	-
P265GH	1.0425	890 to 950 ^a	-	-
P295GH	1.0481	890 to 950 ^a	-	-
P355GH	1.0473	890 to 950 ^a	-	-
16Mo3	1.5415	890 to 950 ^a	-	c
18MnMo4-5	1.5414	890 to 950		600 to 640
20MnMoNi4-5	1.6311	-	870 to 940	610 to 690
15NiCuMoNb5-6-4	1.6368	880 to 960		580 to 680
13CrMo4-5	1.7335	890 to 950		630 to 730
13CrMoSi5-5	1.7336	890 to 950		650 to 730
10CrMo9-10	1.7380	920 to 980		650 to 750
12CrMo9-10	1.7375	920 to 980		650 to 750
X12CrMo5	1.7362	920 to 970		680 to 750
13CrMoV9-10	1.7703	930 to 990		675 to 750
12CrMoV12-10	1.7767	930 to 1000		675 to 750
X10CrMoVNb9-1	1.4903	1040 to 1100		730 to 780
^a When normalizing, after the required temperatures have been attained over the whole cross-section, no further holding is necessary and should be generally avoided. ^b When tempering, the specified temperatures shall, when they have been attained over the whole cross-section, be maintained for an appropriate time. ^c In certain cases, tempering at 590 °C to 650 °C may be necessary.				

Annex B (informative)

Critical time temperature parameter $P_{crit.}$ and possible combinations of stress relieving temperature and holding time

Examples for stress relieving temperatures and the corresponding maximum holding time calculated on the basis of the equation in 8.2.4 for a given critical time temperature parameter $P_{crit.}$ are given in Table B.1.

Table B.1 — $P_{crit.}$ value and permissible holding time for a given stress relieving temperature

Steel type or steel grade	$P_{crit.}$	$P_{crit.}$ condition fulfilled with stress relieving temperature in °C for a holding time ^a of	
		1 h	2 h
C, CMn steels	17,3	580	575
16Mo3	17,5	590	585
18MnMo4-5	17,5	590	585
20MnMoNi4-5	17,5	590	585
15NiCuMoNb5-6-4	17,5	590	585
13CrMo4-5	18,5	640	630
13CrMoSi5-5	18,7	650	640
10CrMo9-10	19,2	675	665
12CrMo9-10	19,3	680	670
X12CrMo5	19,5	690	680
13CrMoV9-10	19,4	685	675
12CrMoV12-10	19,4	685	675
X10CrMoVNb9-1	20,5	740	730
^a Selected pairs of stress relieving temperature and holding time for guidance.			

Annex C (informative)

Reference data of strength for 1 % (plastic) creep strain and creep rupture

NOTE 1 The values given in Table C.1 were derived as mean values in accordance with ISO 6303 with a scatter band of $\pm 20\%$.

NOTE 2 The strength values for 1% (plastic) creep strain and creep rupture given up to the elevated temperatures listed in Table C.1 do not mean that the steels can be used in continuous duty up to these temperatures. The governing factor is the total stressing during operation. Where relevant, the oxidation conditions should also be taken into account.

Table C.1 — Strength for 1% (plastic) creep strain and creep rupture

Steel grade		Temperature °C	Strength for 1% (plastic) creep strain in MPa for		Creep rupture strength in MPa for		
name	number		10 000 h	100 000 h	10 000 h	100 000 h	200 000 h
P235GH, P265GH	1.0345, 1.0425	380	164	118	229	165	145
		390	150	106	211	148	129
		400	136	95	191	132	115
		410	124	84	174	118	101
		420	113	73	158	103	89
		430	101	65	142	91	78
		440	91	57	127	79	67
		450	80	49	113	69	57
		460	72	42	100	59	48
		470	62	35	86	50	40
		480	53	30	75	42	33
P295GH, P355GH	1.0481, 1.0473	380	195	153	291	227	206
		390	182	137	266	203	181
		400	167	118	243	179	157
		410	150	105	221	157	135
		420	135	92	200	136	115
		430	120	80	180	117	97
		440	107	69	161	100	82
		450	93	59	143	85	70
		460	83	51	126	73	60
		470	71	44	110	63	52
		480	63	38	96	55	44
16Mo3	1.5415	490	55	33	84	47	37
		500	49	29	74	41	30
		450	216	167	298	239	217
		460	199	146	273	208	188
		470	182	126	247	178	159
		480	166	107	222	148	130
		490	149	89	196	123	105
		500	132	73	171	101	84
		510	115	59	147	81	69
520	99	46	125	66	55		
530	84	36	102	53	45		

Table C.1 (continued)

Steel grade		Temperature °C	Strength for 1% (plastic) creep strain in MPa for		Creep rupture strength in MPa for		
name	number		10 000 h	100 000 h	10 000 h	100 000 h	200 000 h
18MnMo4-5	1.5414	425	392	314	421	343	
		430	383	302	407	330	
		440	360	272	380	300	
		450	333	240	353	265	
		460	303	207	325	230	
		470	271	176	295	196	
		480	239	148	263	166	
		490	207	124	229	140	
		500	177	103	196	118	
		510	150	84	165	98	
20MnMoNi4-5	1.6311	520	127	64	141	79	
		525	118	54	132	69	
		450			290	240	
		460			272	211	
		470			251		
15NiCuMoNb 5-6-4	1.6368	480			225		
		490			194		
		400	324	294	402	373	
		410	315	279	385	349	
		420	306	263	368	325	
		430	295	245	348	300	
		440	281	227	328	273	
		450	265	206	304	245	
		460	239	180	274	210	
		470	212	151	242	175	
13CrMo4-5	1.7335	480	180	120	212	139	
		490	145	84	179	104	
		500	108	49	147	69	
		450	245	191	370	285	260
		460	228	172	348	251	226
		470	210	152	328	220	195
		480	193	133	304	190	167
		490	173	116	273	163	139
		500	157	98	239	137	115
		510	139	83	209	116	96
		520	122	70	179	94	76
		530	106	57	154	78	62
		540	90	46	129	61	50
550	76	36	109	49	39		
560	64	30	91	40	32		
570	53	24	76	33	26		

Table C.1 (continued)

Steel grade		Temperature °C	Strength for 1% (plastic) creep strain in MPa for		Creep rupture strength in MPa for		
name	number		10 000 h	100 000 h	10 000 h	100 000 h	200 000 h
13CrMoSi5-5	1.7336	450		209		313	
		460		200		300	
		470		185		278	
		480		141		212	
		490		119		179	
		500		113		169	
		510		81		122	
		520		66		99	
		530		41		62	
		540		33		50	
		550		27		40	
		560		23		35	
		570		21		31	
		10CrMo9-10	1.7380	450	240	166	306
460	219			155	286	205	186
470	200			145	264	188	169
480	180			130	241	170	152
490	163			116	219	152	136
500	147			103	196	135	120
510	132			90	176	118	105
520	119			78	156	103	91
530	107			68	138	90	79
540	94			58	122	78	68
550	83			49	108	68	58
560	73			41	96	58	50
570	65			35	85	51	43
580	57			30	75	44	37
590	50	26	68	38	32		
600	44	22	61	34	28		
12CrMo9-10	1.7375	400			382	313	
		410			355	289	
		420			333	272	
		430			312	255	
		440			293	238	
		450			276	221	
		460			259	204	
		470			242	187	
		480			225	170	
		490			208	153	
		500			191	137	
		510			174	122	
520			157	107			

Table C.1 (continued)

Steel grade		Temperature °C	Strength for 1% (plastic) creep strain in MPa for		Creep rupture strength in MPa for		
name	number		10 000 h	100 000 h	10 000 h	100 000 h	200 000 h
X12CrMo5	1.7362		107				
		460	96		147 (475°C)		
		470	87				
		480	83			139	
		490	78			123	
		500	70			108	
		510	56		94		
		520	50		81		
		530	44		71		
		540	39		61		
		550	35		53		
		560	31		47		
		570	27		41		
		580	24		36		
		590	21		32		
		600	18		27		
		610	16				
		620	14				
		625	13				
13CrMoV9-10	1.7703	400			430	383	
		410			414	365	
		420			397	346	
		430			380	327	
		440			362	309	
		450			344	290	
		460			326	271	
		470			308	253	
		480			290	235	
		490			272	218	
		500			255	201	
		510			237	184	
		520			221	169	
530			204	144			
540			188	126			
550			173	108			

Table C.1 (continued)

Steel grade		Temperature °C	Strength for 1% (plastic) Creep strain in MPa for		Creep rupture strength in MPa for		
name	number		10 000 h	100 000 h	10 000 h	100 000 h	200 000 h
12CrMoV12-10	1.7767	400			430	383	
		410			414	365	
		420			397	346	
		430			380	327	
		440			362	309	
		450			344	290	
		460			326	271	
		470			308	253	
		480			290	235	
		490			272	218	
		500			255	201	
		510			237	184	
		520			221	169	
		530			204	144	
		540			188	126	
X10CrMoVNb 9-1	1.4903	550			289	258	246
		510			271	239	227
		520			252	220	208
		530			234	201	189
		540			216	183	171
		550			199	166	154
		560			182	150	139
		570			166	134	124
		580			151	120	110
		590			136	106	97
		600			123	94	86
		610			110	83	75
		620			99	73	65
		630			89	65	57
		640			79	56	49
650			70	49	42		
660			62	42	35		
670			55	36	-		

Annex D (normative)

Evaluation of resistance to hydrogen induced cracking

The tests to evaluate the resistance of steel products to hydrogen induced cracking shall be performed in accordance with EN 10229. The acceptance criteria for the test solution A (with pH 3) apply for the classes indicated in Table D.1 where the given values are mean values from three individual test results.

Test solution B (with pH 5) and corresponding acceptance criteria may be agreed at the time of enquiry and order.

Table D.1 – Acceptance classes for the HIC test (test solution A)

Acceptance class	CLR ^a %	CTR ^a %	CSR ^a %
I	5	1,5	0,5
II	10	3	1
III	15	5	2
^a CLR: crack length ratio, CTR: crack thickness ratio, CSR: crack sensitivity ratio			

Annex E (normative)

Step cooling test

For the step cooling test a procedure to check step cooling embrittlement shall be agreed. This procedure shall include temperatures and holding times to be considered. The procedure given in Figure E.1 is recommended.

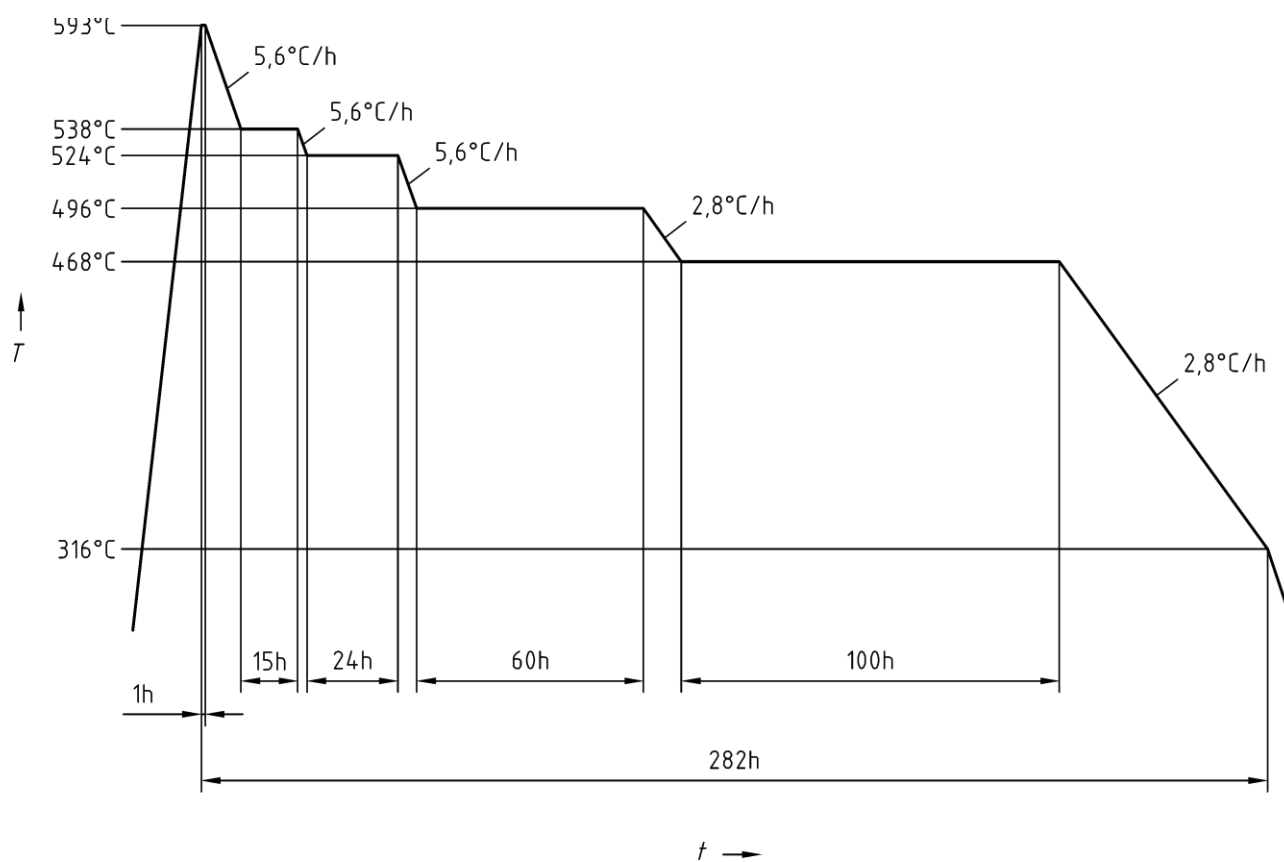

Figure E.1 — Recommended procedure for the step cooling test

Annex ZA (informative)

Relationship between this European Standard and the Essential Requirements of EU Directive 97/23/EC

This European Standard has been prepared under a mandate given to CEN by the European Commission and the European Free Trade Association to provide a means of conforming to Essential Requirements of the New Approach Directive 97/23/EC .

Once this standard is cited in the Official Journal of the European Communities under that Directive and has been implemented as a national standard in at least one Member State, compliance with the clauses of this standard given in Table ZA.1 confers, within the limits of the scope of this standard, a presumption of conformity with the corresponding Essential Requirements of that Directive and associated EFTA regulations.

Table ZA.1 – Correspondence between this European Standard and Directive 97/23/EC

Clause(s)/sub-clause(s) of this EN	Essential Requirements (ERs) of Directive 97/23/EC
All normative clauses	Annex 1, section 4

WARNING : Other requirements and other EU Directives may be applicable to the product(s) falling within the scope of this standard.

Bibliography

EN 1011-1, *Welding - Recommendations for welding of metallic materials – Part 1: General guidance for arc welding.*

EN 1011-2, *Welding - Recommendations for welding of metallic materials – Part 2: Arc welding of ferritic steels.*

EN 10020, *Definition and classification of grades of steel.*

EN 10314, *Method for the derivation of minimum values of proof strength of steel at elevated temperatures.*

ISO 6303, *Pressure vessel steels not included in ISO 2604, Parts 1 to 6 – Derivation of long-time stress rupture properties.*

BSI — British Standards Institution

BSI is the independent national body responsible for preparing British Standards. It presents the UK view on standards in Europe and at the international level. It is incorporated by Royal Charter.

Revisions

British Standards are updated by amendment or revision. Users of British Standards should make sure that they possess the latest amendments or editions.

It is the constant aim of BSI to improve the quality of our products and services. We would be grateful if anyone finding an inaccuracy or ambiguity while using this British Standard would inform the Secretary of the technical committee responsible, the identity of which can be found on the inside front cover. Tel: +44 (0)20 8996 9000. Fax: +44 (0)20 8996 7400.

BSI offers members an individual updating service called PLUS which ensures that subscribers automatically receive the latest editions of standards.

Buying standards

Orders for all BSI, international and foreign standards publications should be addressed to Customer Services. Tel: +44 (0)20 8996 9001. Fax: +44 (0)20 8996 7001. Email: orders@bsi-global.com. Standards are also available from the BSI website at <http://www.bsi-global.com>.

In response to orders for international standards, it is BSI policy to supply the BSI implementation of those that have been published as British Standards, unless otherwise requested.

Information on standards

BSI provides a wide range of information on national, European and international standards through its Library and its Technical Help to Exporters Service. Various BSI electronic information services are also available which give details on all its products and services. Contact the Information Centre. Tel: +44 (0)20 8996 7111. Fax: +44 (0)20 8996 7048. Email: info@bsi-global.com.

Subscribing members of BSI are kept up to date with standards developments and receive substantial discounts on the purchase price of standards. For details of these and other benefits contact Membership Administration. Tel: +44 (0)20 8996 7002. Fax: +44 (0)20 8996 7001. Email: membership@bsi-global.com.

Information regarding online access to British Standards via British Standards Online can be found at <http://www.bsi-global.com/bsonline>.

Further information about BSI is available on the BSI website at <http://www.bsi-global.com>.

Copyright

Copyright subsists in all BSI publications. BSI also holds the copyright, in the UK, of the publications of the international standardization bodies. Except as permitted under the Copyright, Designs and Patents Act 1988 no extract may be reproduced, stored in a retrieval system or transmitted in any form or by any means – electronic, photocopying, recording or otherwise – without prior written permission from BSI.

This does not preclude the free use, in the course of implementing the standard, of necessary details such as symbols, and size, type or grade designations. If these details are to be used for any other purpose than implementation then the prior written permission of BSI must be obtained.

Details and advice can be obtained from the Copyright & Licensing Manager. Tel: +44 (0)20 8996 7070. Fax: +44 (0)20 8996 7553. Email: copyright@bsi-global.com.